



**How to Attach
Butler Robotics to a
Handi Quilter/Baby lock
with Studio, Fusion,
Pearl, or Momentum
Frame**

In order to accommodate all machine types we use universal parts bags, not all parts will be used in every installation.

Bag #

Contents

Picture

Cables

Vary by machine



X1

1 - White belt (15')

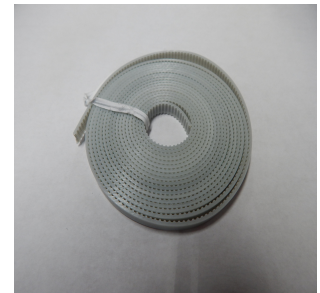

Y1

1 - Black Belt (86")



Z1

1 0 - Plastic Anchors
2- Screw (M5 x 12mm)
2- Washer (M5)
10- 5" Zip ties
5- 10" Zip ties



Z3

1 - Motor Pulley Cover
2 - Nuts (M5 K-Lock)



Bag

Contents

Picture

D5

- 1 - Universal Display Bracket
- 4 - Screw (M6 x 8mm)
- 4 - Nut (M6)
- 2 - Screw (8-32 x 0.5)
- 2 - Poly disc washers
- 2- Screw (M4 x 20mm)
- 2- Washer
- 3- Hex head bolts (M6 x 45mm)



I8

- 1- Rear idler bracket
- 1- Tensioner bracket
- 2- Lock nut (1/4"-20)
- 2- Machine screw (1/4"-20 x 1")
- 1- Pulley assembly



Y13

- 1- Carriage bracket
- 1- Pan-head screw (#10-24 x 1/4")
- 1- Thumb screw (#10-24 x 1/2")
- 2- Pan-head screw (#10-24 x 1/2")
- 1- Y-belt bracket

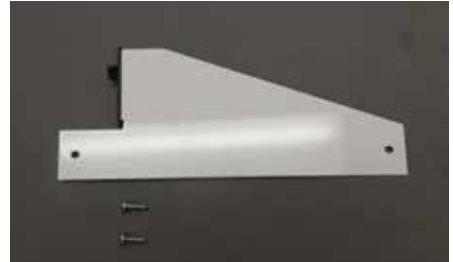

**X7 (Studio Frame)
or
X5 (Pearl/Momentum)**

- 2- X-belt Bracket
- 2- Eye bolt (M5 x 40mm)
- 4- Locknut (M5)



M8

- 1- Motor box bracket
- 2- Lock nut (1/4"-20)
- 2- Screw (1/4"-20 x 1")



Attach the Front Carriage Bracket (Bag M8)

- 1** Attach the front carriage bracket to black motor box using the provided M5 x 12mm screws.

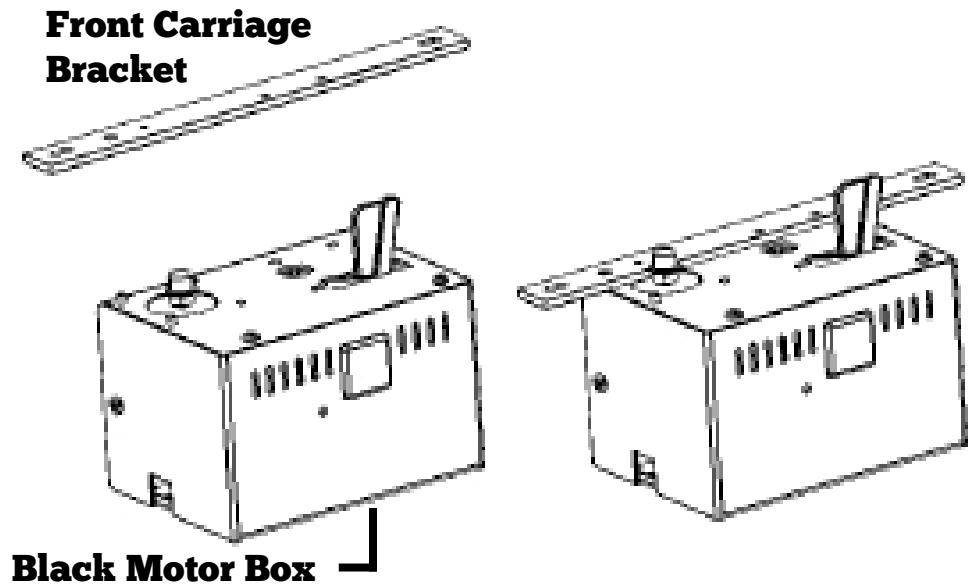

- 2** Install the motor box bracket underneath the front of the carriage. Line the holes on the bracket with the existing holes on the carriage.

Fasten in place with the provided 1/4"-20 x 1" screws

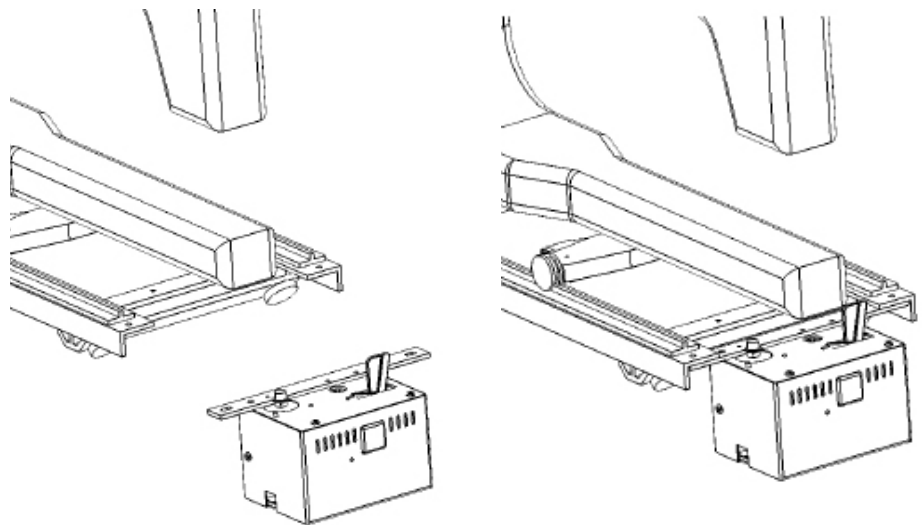

Attach the Rear Idler Bracket (Bag I8)

- 1** Line the idler bracket with the existing holes on the rear of the carriage and attach it using the provided 1/4"-20 x 1" screws

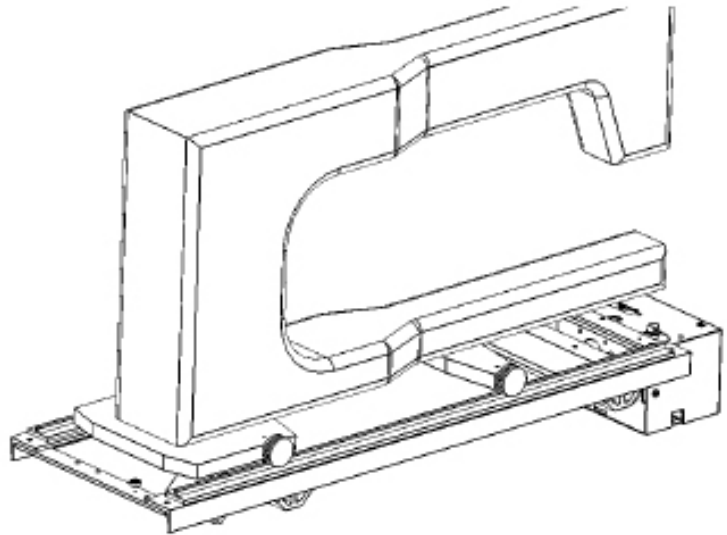
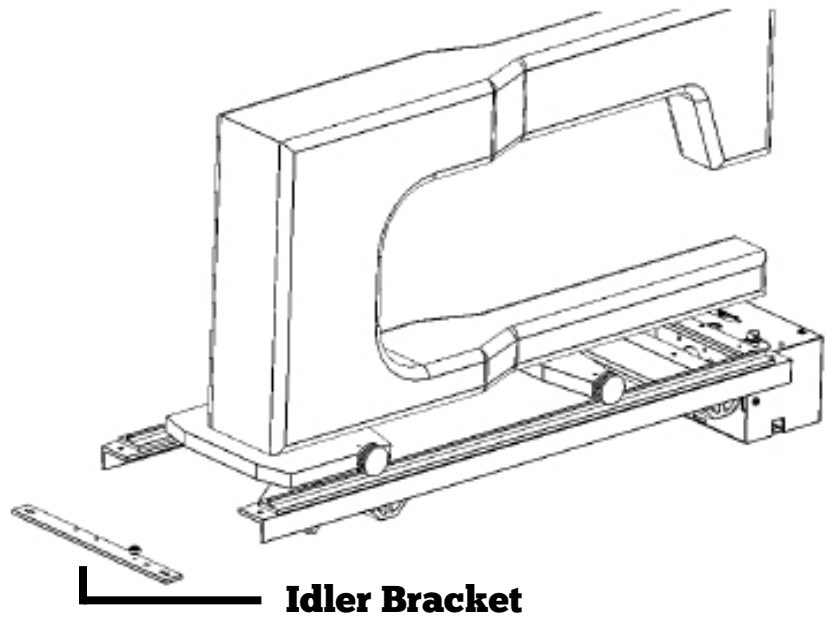

Install Black Belt (Bag Y1 and Bag Y13)

- 1 Attach the two black belt brackets together using the provided winged screw and screw.

If the bracket is pre-installed continue to step 2.

Insert the winged-screw from the front and the normal screw from the back.

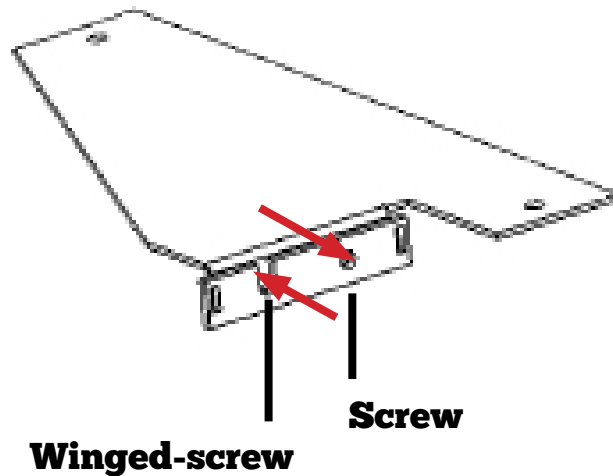
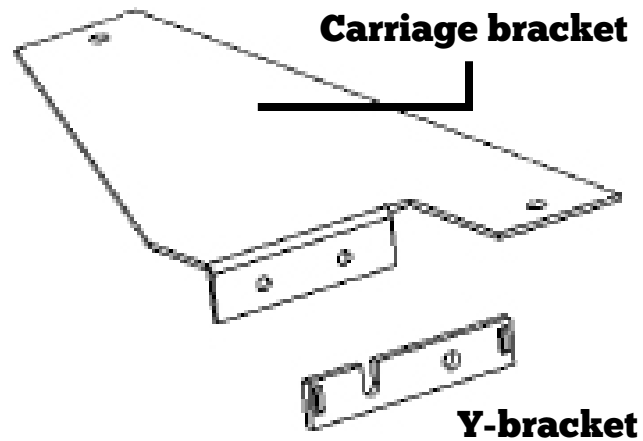

- 2** Install black belt assembly to the underside of the front carriage wheels.

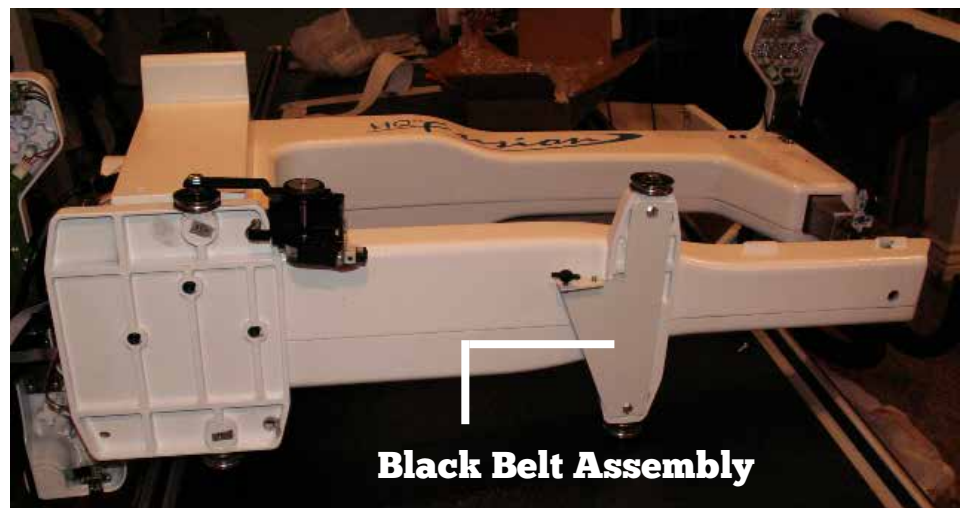
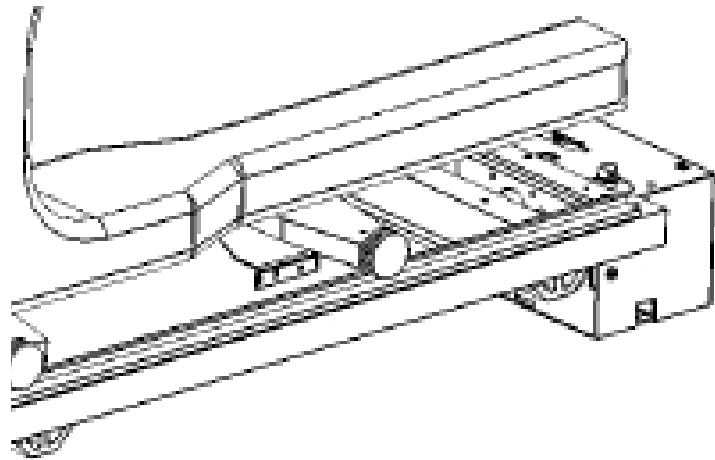
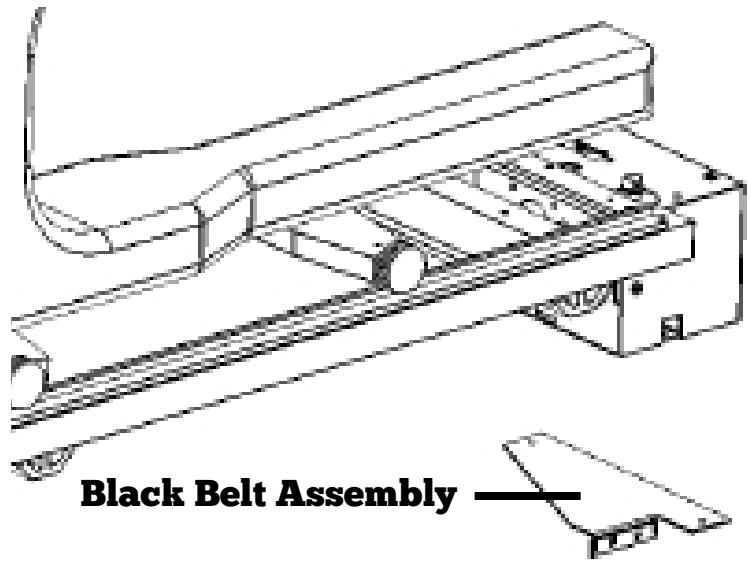

- 3** Use the belt clamps to attach one side of the black belt to the Y-bracket. Make sure the teeth face away from the carriage.

See Appendix A for help with belt clamps.



- 4** Loop the belt around the motor pulley with the teeth facing in.

The uninterrupted length of the belt will run farther from the carriage.

Then loop the belt around the rear idler pulley.

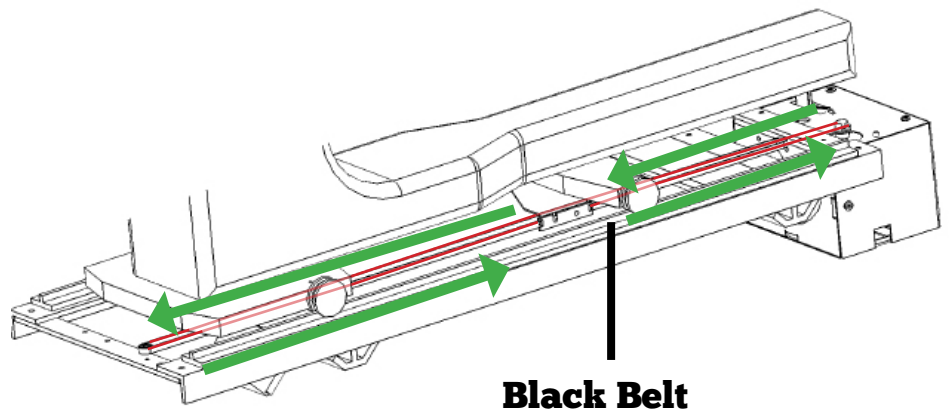

- 5** Attach the other end of the belt to the Y-bracket using another belt clamp.

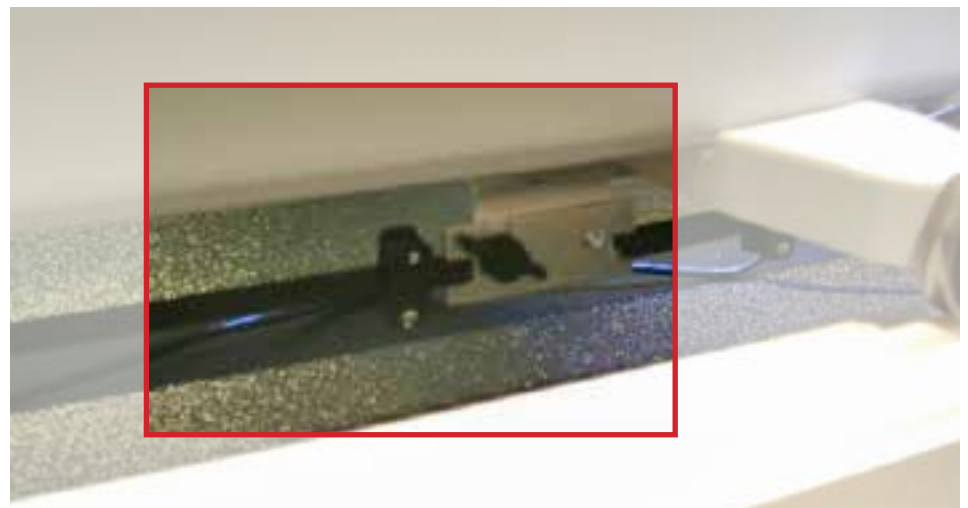

Install White Belt on Handi Quilter Studio Frame (Bag X1 and Bag X7)

- 1** Remove the screws indicated to the right from the frame.



- 2** Position the bracket onto the frame and use the screws removed in step one to secure it to the frame. Offset the screws in the slots so that the bracket rests vertically.

Repeat for the opposite side.

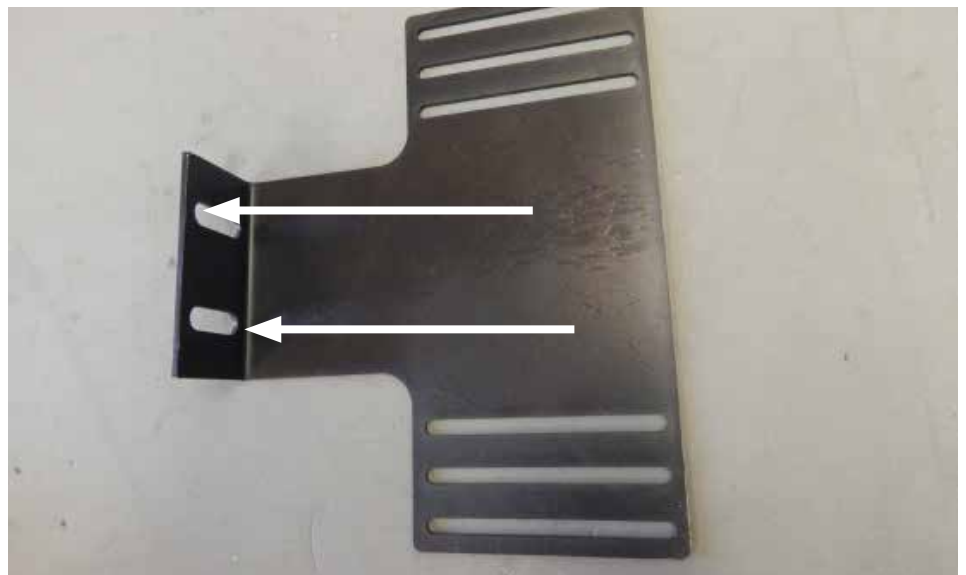

- 3** Attach the eye bolt into one of the slotted holes on the bracket so that it is in line with the pulley on the back of the motor box.



- 4** Loop the white belt through the eye on the bolt, and secure with a belt clamp.

Repeat for the opposite side.

See Appendix A for help with belt clamps.



- 5** Release the belt lock lever and run the belt as shown with the teeth facing up.

Then reengage the lock lever.

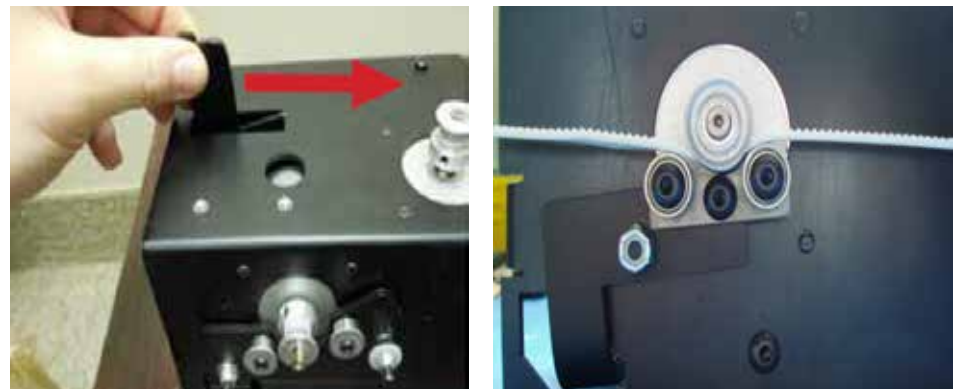

Install White Belt on Handi Quilter Fusion Frame (Bag X1 and Bag X7)

- 1** Attach the clamp brackets to the using the provided screws.

Make sure that they are inline with the pulley on the back of the motor box.

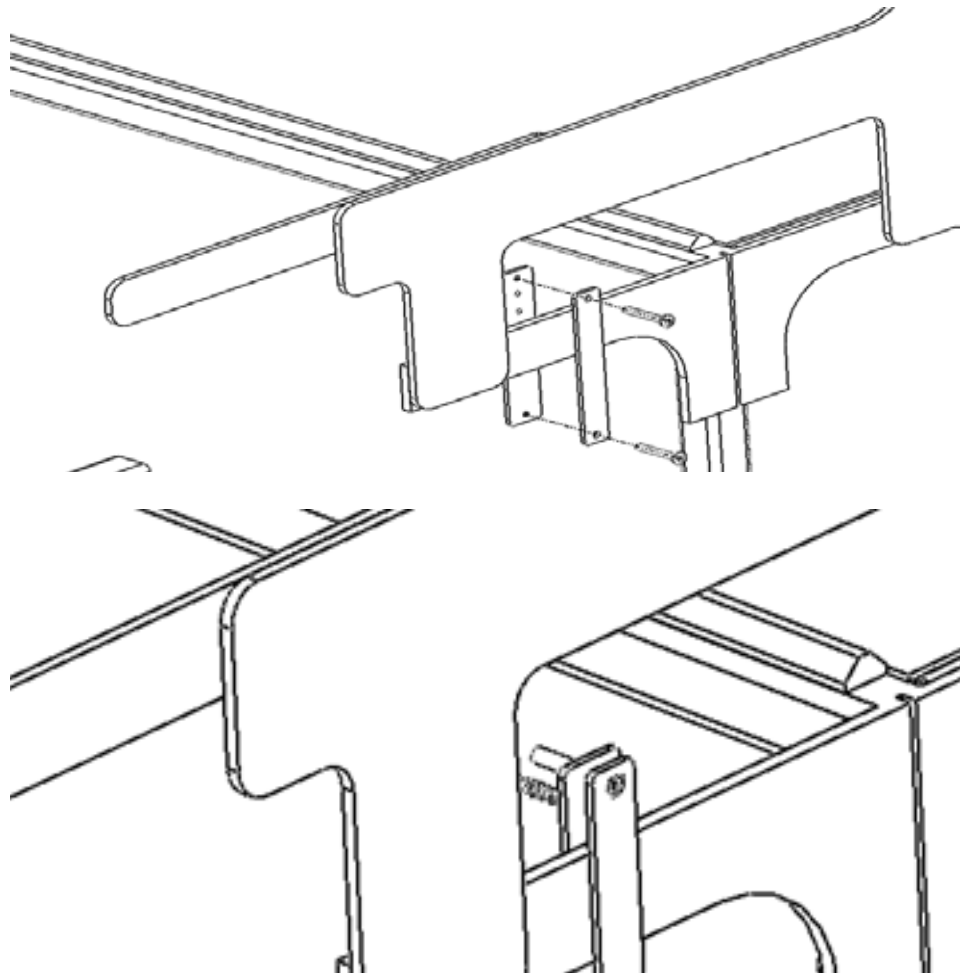

- 2** Attach the eyebolt to the inner clamp with one of the lock nuts on each side of the clamp.

Repeat for both sides.

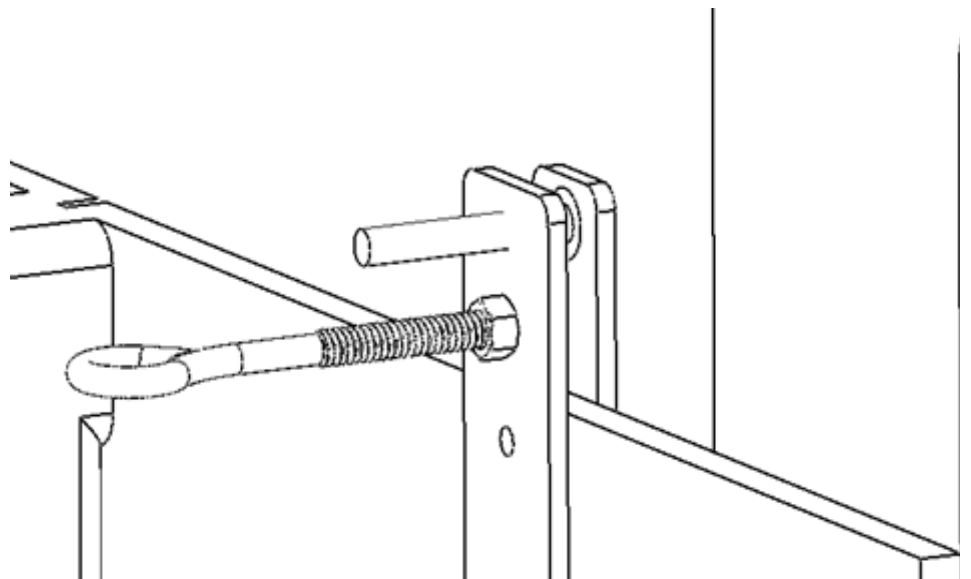

3 Use a belt clamp to secure the belt to each of the eyebolts.

Release the belt lock lever and run the belt as shown with the teeth facing up.

Then reengage the lock lever.

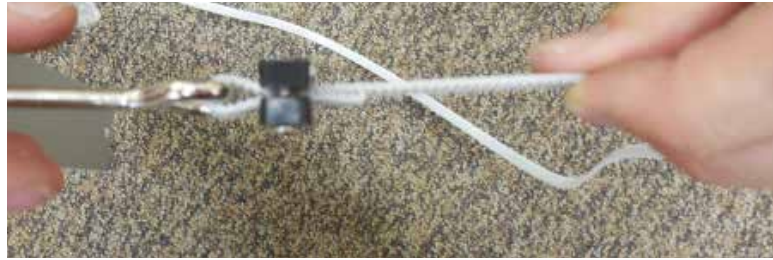

Install White Belt on Baby Lock Pearl Frame (Bag X1 and Bag X5)

- 1** Clamp the white belt brackets onto the each end of the frame using the provided long screws.

(Level the belt and brackets with the pulley on motor box.)



- 2** Attach the white belt to the eye-bolt using the belt clamps to install onto the belt bracket.

Install the eye-bolt into one belt bracket, stretch white belt the length of the frame, belt teeth facing up.

Attach the other end of the white belt to the remaining eye-bolt and install into opposite belt bracket. (Use the belt clamp to eliminate excess belt length.)



- 3** Release the belt lock lever and run the belt as shown with the teeth facing up.

Then reengage the lock lever.

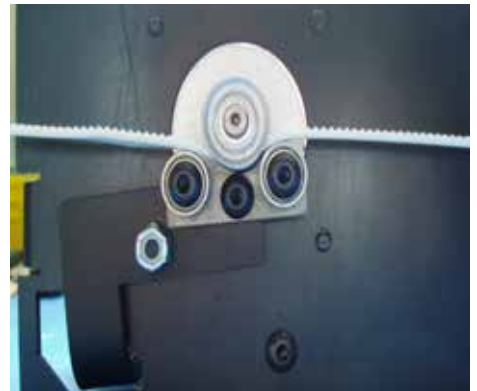

Install White Belt on Baby Lock Momentum Frame (Bag X1 and Bag X5)

- 1** Clamp the white belt brackets onto the each end of the frame using the provided long screws.

(Level the belt and brackets with the pulley on motor box.)



2 Attach the white belt to the eye-bolt using the belt clamps to install onto the belt bracket.

Install the eye-bolt into one belt bracket, stretch white belt the length of the frame, belt teeth facing up.

Attach the other end of the white belt to the remaining eye-bolt and install onto opposite belt bracket. (Use the belt clamp to eliminate excess belt length.)



*Images not representative of Momentum frame

3 Release the belt lock lever and run the belt as shown with the teeth facing up.

Then reengage the lock lever.



Install Display (Bag D5)

- 1** Remove the 3 screws holding the handle to the machine.

Then line up the display bracket with the three holes.



- 2** Use the three M6 x 45mm bolts to attach the display to the machine.



- 3** Refer the to Android Installation Guide to install the tablet onto the display bracket.



- 4** For standard displays, use the provided screws to attach the display to the bracket.



Connect Cables

- 1** Attach one end of the network cable to the Remote port on the Motor box.

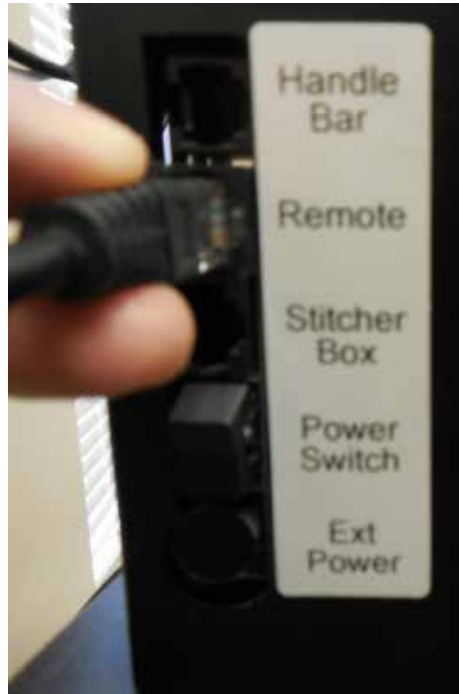

- 2** Run the cable around the back of the machine up to the display.

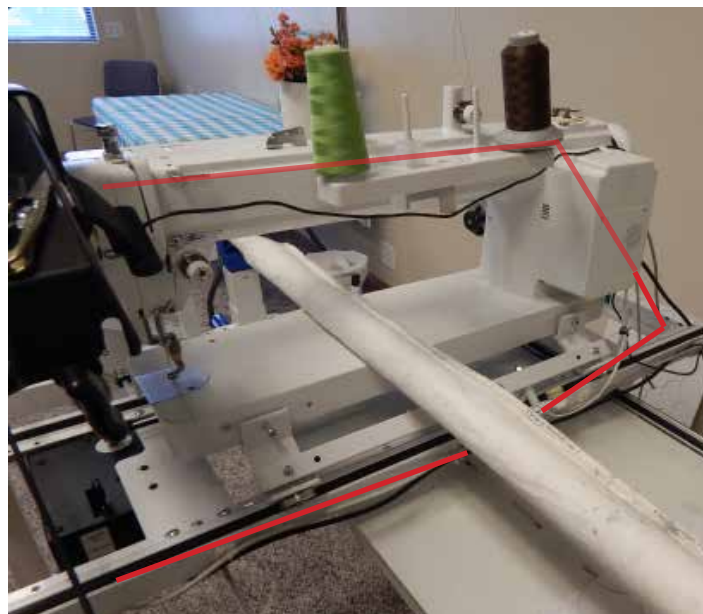

*Image not representative of machine type.

3

Connect the other end of the display cable into the display.

Android cables will plug into the RJ45 network connection on the hub on the back of the tablet.

Standard displays will plug into the slot on the bottom of the display.



4

Plug the phone style RJ12 side of the handlebar cable into the handlebar port on the motor box.

Follow the display cable around the back of the machine.



- 5** Use the anchors and zip-ties from bag Z1 to secure the cables to the carriage and the machine in such a way that they will not be in the way of moving parts.



*Image not representative of frame type.

- 6** Avante:
Remove the handlebar wires from the machine.

Plug the handlebar wires from the machine into the provided handlebar cable adapter.

Plug the adapter with the handlebar wires into the machine.



Check Belt Tension

- 1** Set the machine in the middle of the frame.

The white belt should have between 1" and 1.5" of play in the belt.

The black belt should have approximately 1/4" of play.



*Images not representative of frame type.

2 Loosen the nut on the eye-bolt that is on the inside then tighten the nut that is on the outside to adjust the tension of the white belt.

The belt clamps may need to be readjusted.



*Images not representative of frame type.

3 Adjust the tensioner bracket on the rear idler pulley to adjust the tension of the black belt.

Loosen the screw on the pulley, adjust the tension, then tighten the screw back down.

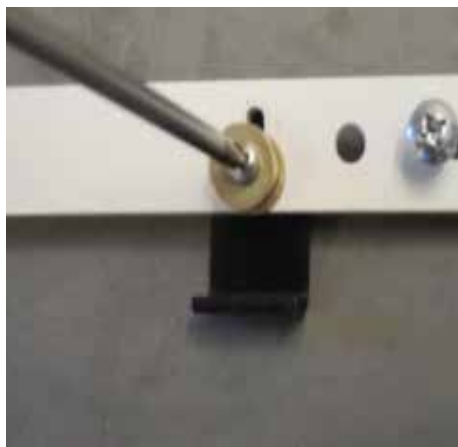

*Bracket removed from frame for display purposes, bracket may vary in appearance.

Set Machine Type

Important: If the machine has been upgraded to PerfectStitch, then the machine type is to be set to Default.

Android Tablet

1

Power on the display, go to Settings > Machine and set the machine type to HQ/Babylock.

Some older HQ machines may need to be set to Juki.

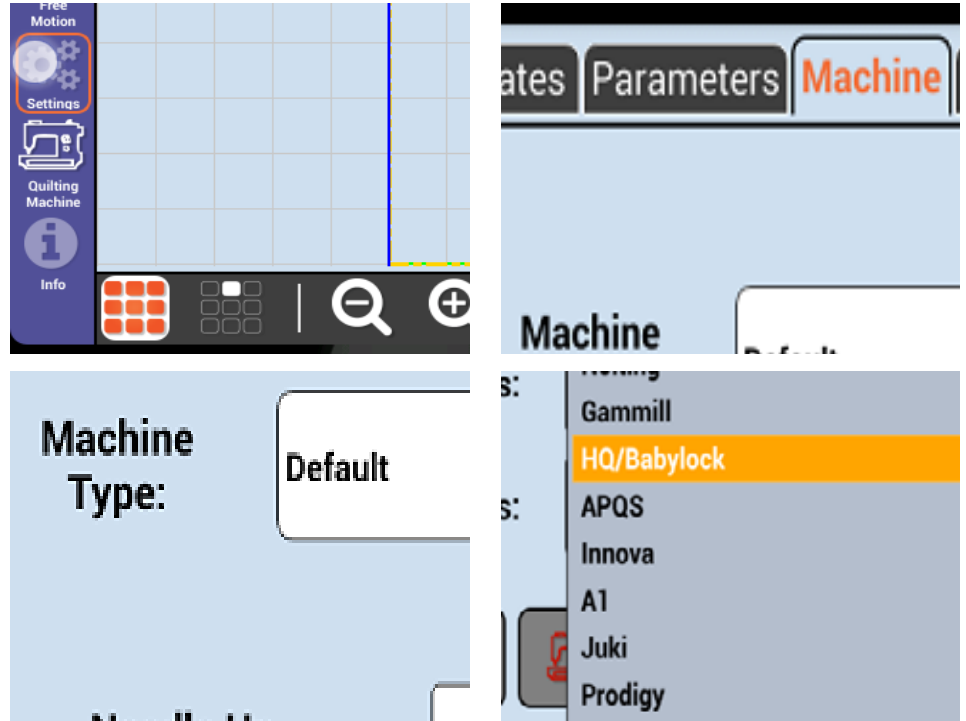

Standard Display

1

Power on the display, go to Setup > Advanced and set the machine type to HQ.

Some older HQ machines may need to be set to Juki.

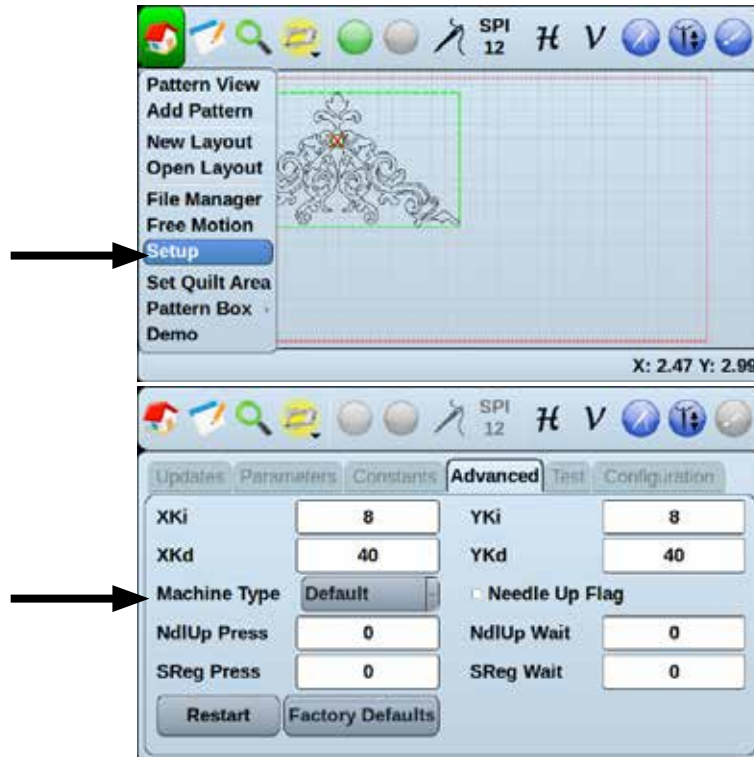

Appendix A - How to use Belt Clamps

A belt clamp consists of two clamps and two screws.



- 1** Using a Phillips screwdriver, insert each screw on opposite sides of the clamps and tighten halfway.

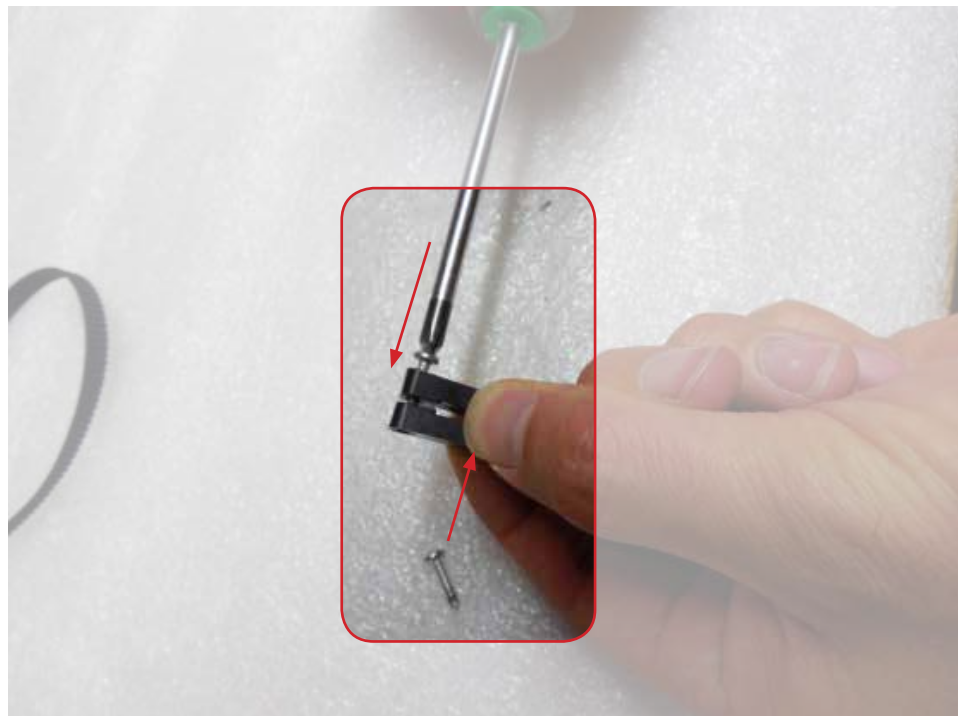

- 2** Thread the belt between the clamps, loop it around and reinsert it between the clamps.



- 3** Align the belt teeth, then finish tightening the clamps.



Appendix B- Additional help

Installing cables

Please refer to the Connecting Robot to Quilt Machine instruction set for help installing cables.

Power on the robotics

Use the power switch located on the side of the motor box with the ports to power the motor box off and on.

Disengage belts for free motion

In order to use free motion with the butler connected the belts will need to be disengaged.

To disengage the x-belt, move the locking lever away from the edge of the motor box.



To disengage the y-belt, loosen the wing-nut on the carriage bracket.

You can now use free motion quilting.



Still need help?

Visit support.quiltez.com for
tutorial videos and additional
help documentation