



How to Attach Butler Robotics to a Gammill Breeze Frame

Bag

Contents

Picture

In order to accommodate all machine types we use universal parts bags, not all parts will be used in every installation.

X1

1-White Belt (15')

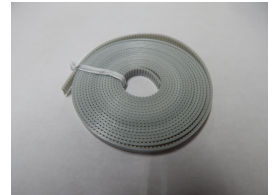

Y1

1 -Black Belt (86")



Z1

10- 5 " Zip Ties
5 - 10 " Zip Ties
10 - Plastic Anchors
2 - Washers (M5)
2 - Screws (M5 x 12mm)



Z3

1 - Motor Pulley Cover
2 - Nuts (M5 K-Lock)



**D3
or
D6**

1 - Universal Display Bracket
4 - Screw (M6 x 8mm)
4 - Nut (M6)
2 - Screw (8-32 x 0.5)
2 - Poly disc washers
2- Screw (M4 x 20mm)
2- Washer



Bag

Contents

Picture

X5

2- Clamp bracket (inside)
2- Clamp bracket (outside)
4- Screw (10-32 x 1/2")
8- Hex nut (10-32)
2- Eye bolt



M7

1- Gammill Breeze motor bracket



Y12

1- Gammill Breeze Y-bracket
1- Y-belt bracket
2- Screw (10-24 x 1/4")
1- Thumb screw (10-24 x 1/2")
2- Screw (M6 x 45MM)



I7

1- Gammill Breeze idler bracket
1- Shoulder Screw (10-24 x 3/4")
1- Timing belt motor pulley
1- Poly disc
2- Screw (M6 x 10mm)



Cables

Cables vary by machine



Attach the Front Carriage Bracket (Bag M7)

- 1** Attach Bracket to top of the motor box with provided screws.

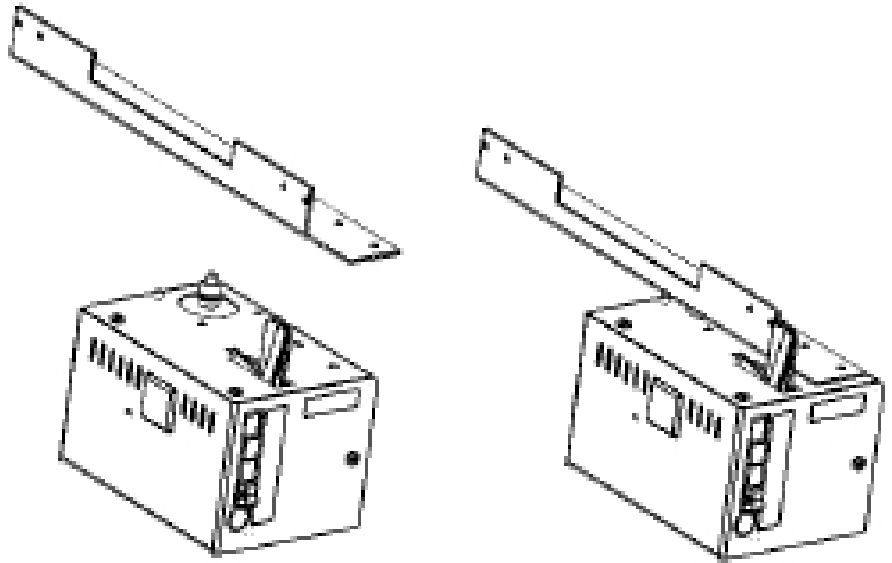

- 2** Attach Bracket to front of carriage with provided screws.

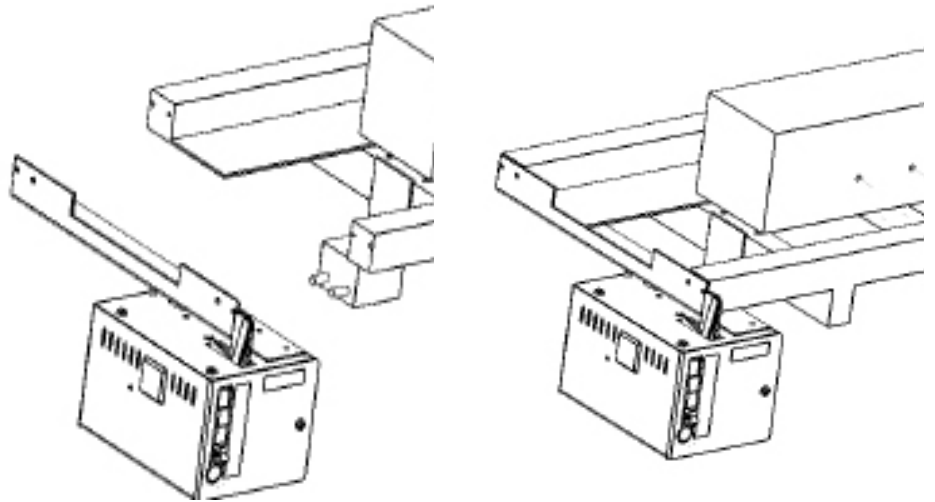

Attach the Rear Idler Bracket (Bag I7)

- 1 Align bracket holes with those on the back of carriage. Screw into place with provided screws.

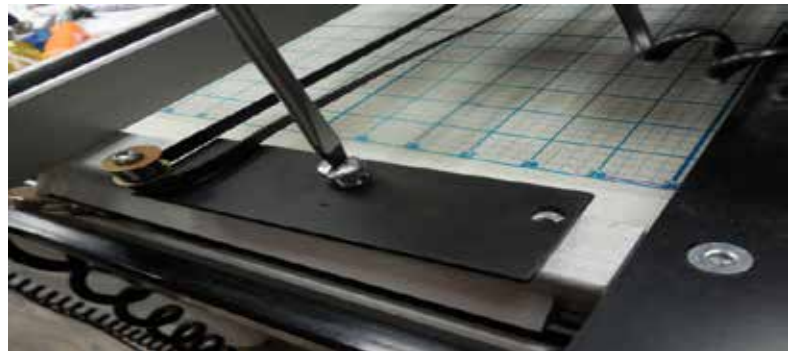
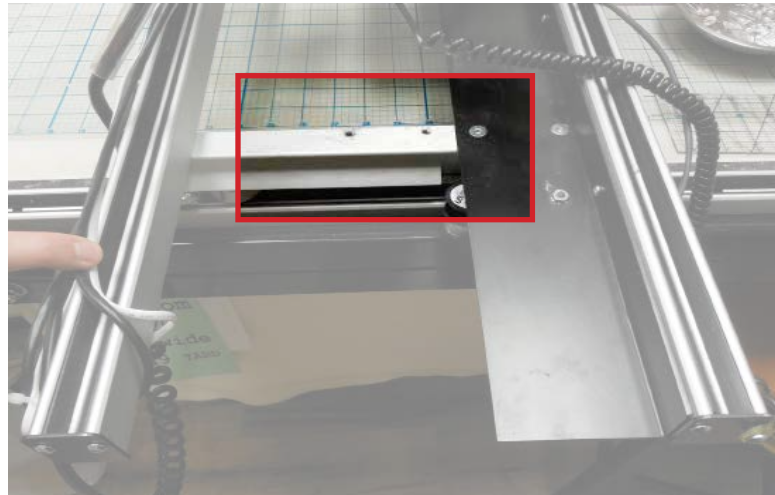

Belt Bracket Assembly (Bag Y1 and Bag Y12)

- 1 Assemble the two black belt brackets and spacers.

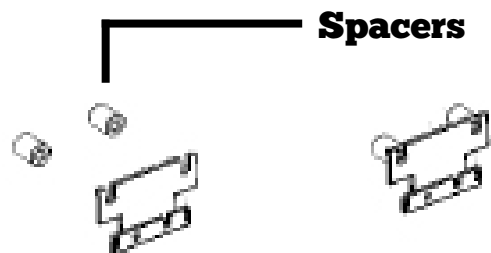
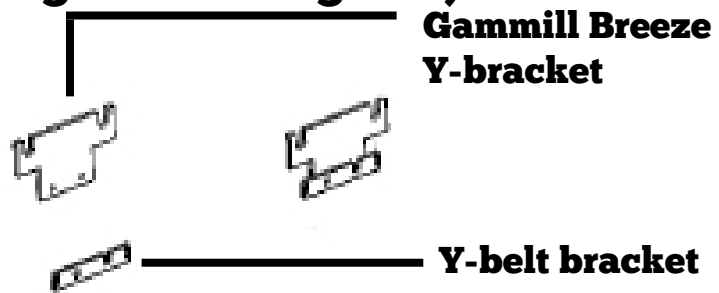

- 2** Remove the laser holder,
Insert belt bracket assembly between the frame and the laser holder
Reattach using laser holder screws.

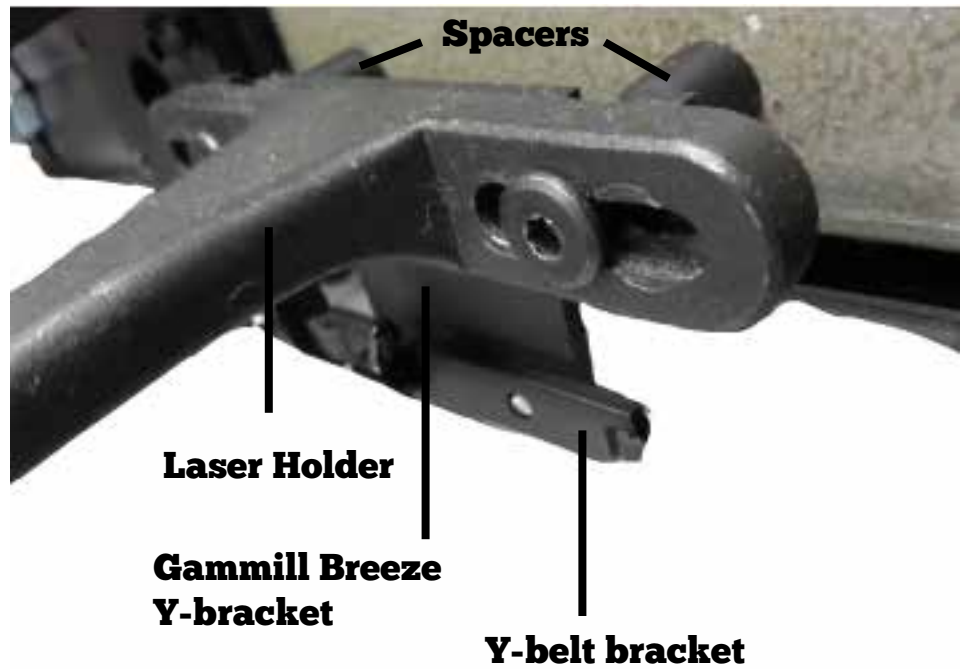

- 3** Use a belt clamp to attach the black belt to the Y-belt bracket with the teeth facing away from the machine.
See Appendix A for belt clamp instructions.

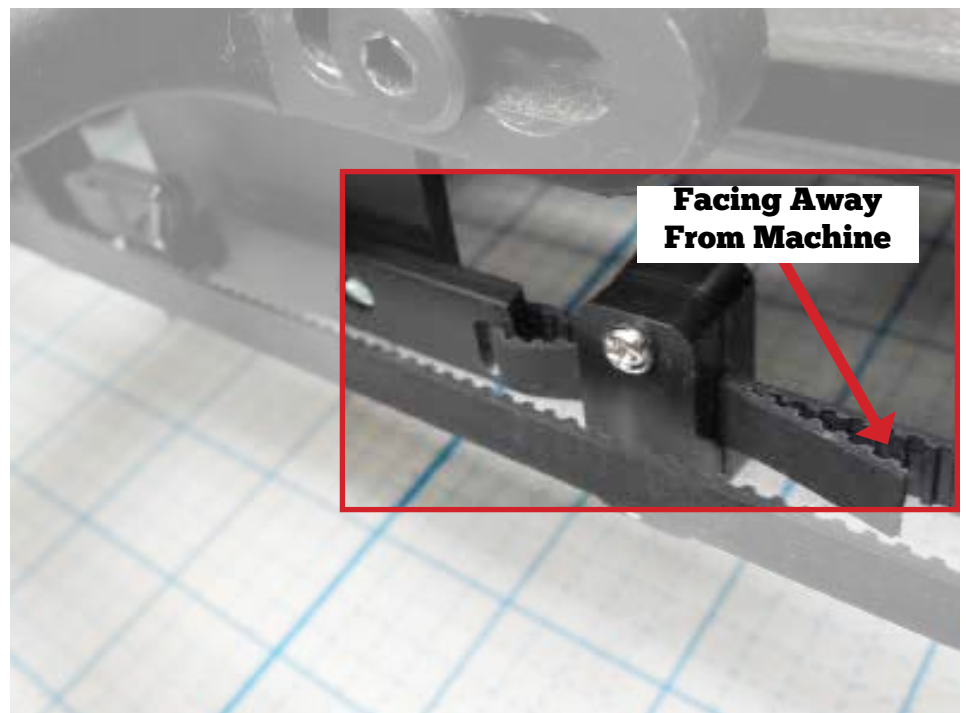

- 4** Loop black belt around the rear idler pulley and up around the top pulley on the motor box with the teeth facing in.



- 5** Attach the end of the belt to the other side of the Y-belt bracket.

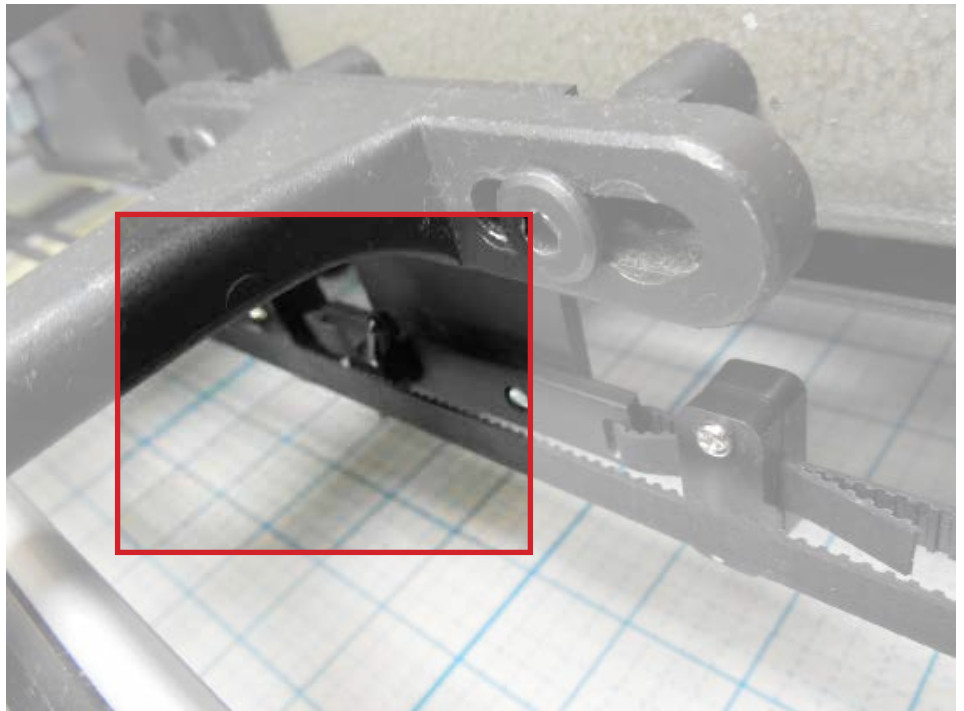

Attach White Belt (Bag X1 and Bag X5)

- 1** Insert the eye bolt into the middle hole of the inner belt bracket.



- 2** Clamp the belt brackets to the frame in such a way that the eye bolt will be in-line with the pulley on the back of the motor box.

Repeat for both sides.

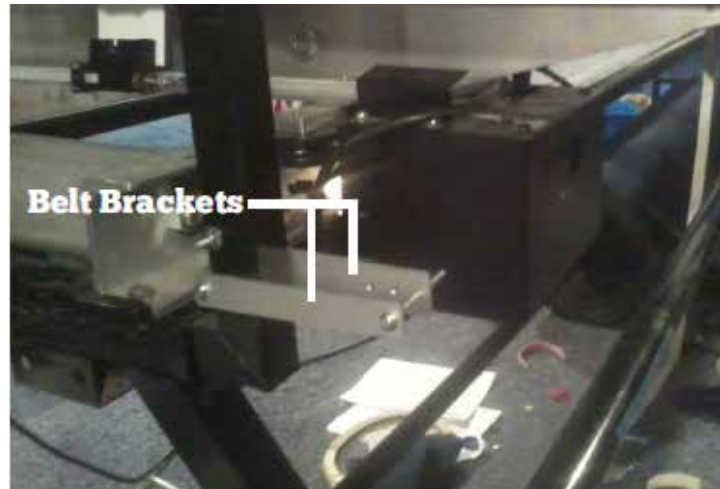

*Two possible configurations displayed



- 3** Use the belt clamps to attach the belt to an eye bolt.

See Appendix A for belt clamp instructions.

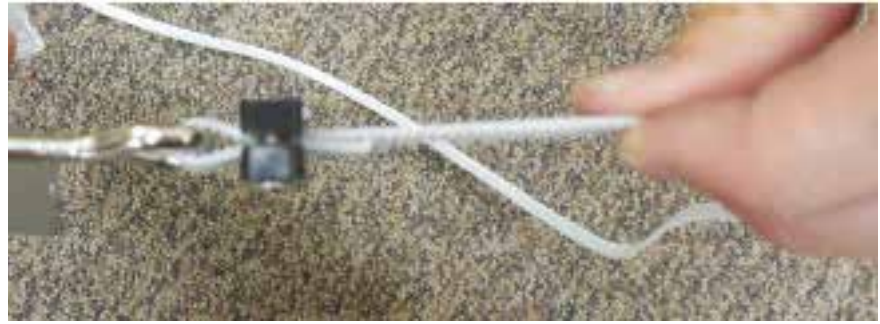

- 4** Release the belt lock lever and run the belt as shown with the teeth facing up.

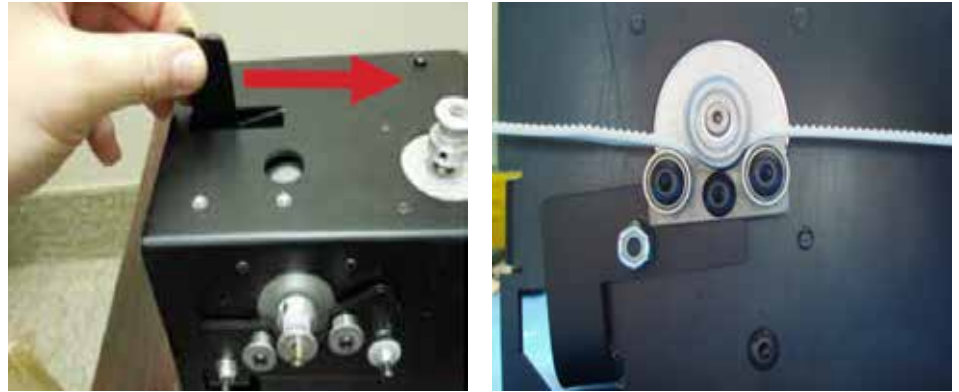

- 5** Use the belt clamps to attach to the eye bolt on the other side.

Reengage the lock lever on the motor box.



- 6** Adjust tension as needed. The belt should have about 1/2" of play with the motor box in the middle of the frame.

Attach Display (Bag D3 or Bag D6)

For outset screws

1 See next page for inset screws.

See page 13 for Vision II machines.

Remove one of the machine head screws at the top of the machine.



Only remove one screw at a time.

2 Slide one side of the bracket over the removed screw hole and Reinstall the removed screw

Repeat for the remaining screw.

Continue to Page 12.

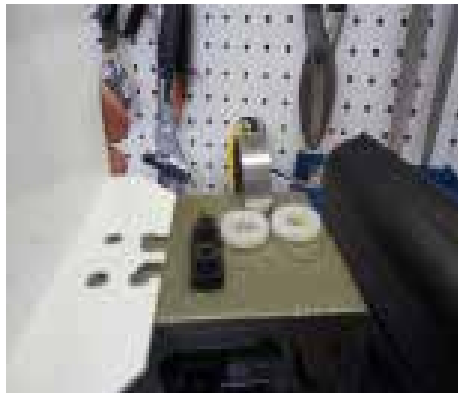

For inset screws

- 1** Remove one of the machine head screws at the top of the machine.

Only remove one screw at a time.

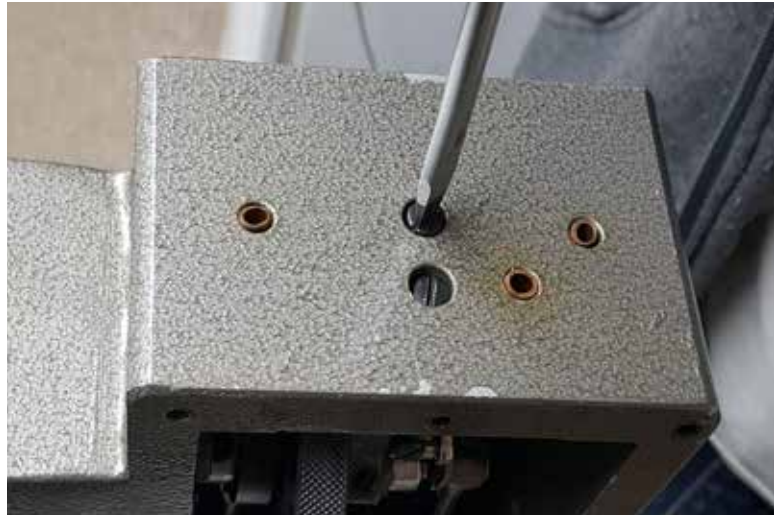

- 2** Slide one side of the bracket under the removed screw and replace it with the provided M4 x 20 screw and washer.

Repeat for the remaining screw.



- 3 Attach the standard display to the bracket with the provided M6 x 8mm screws.

Refer to the *Installing/Troubleshooting Your Android Tablet* guide for help installing the Android Tablet.



For Vision II (Bag D6)

- 1** Locate the two screws on the face of the machine just above the handlebars.



- 2** Hold the handlebars so they do not fall as you remove the two screws.

Insert the display bracket, and reinsert the two screws.



3 Attach the touch screen display to the display bracket.

Android:

Refer to the *Installing/Troubleshooting Your Android Tablet* guide for help installing the Android Tablet.

Standard display:

Use the provided hardware to attach the remote bracket to the remote bases on the display bracket.

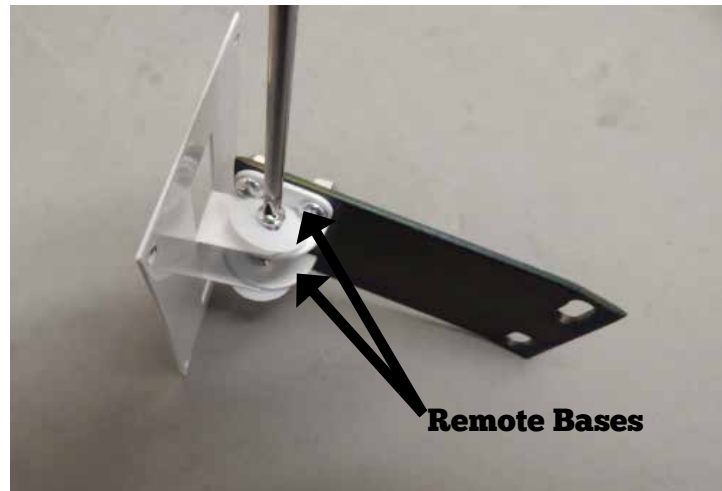

*Bracket removed for display purposes.

Run Cables

1 Run the display cable (shown in thin white at right) along the top of the machine and down to the Black motor box.

Run the white handlebar cable (shown in thick white at right) up from the black motor box back to the rear handle bars.

See page 17 for how to connect handle bar wire to rear handle bar buttons.



2 Use a zip ties and anchor bases to hold cables in place on the top of the machine and the side of the carriage. (Do not tighten zip ties until all wires are in place.)

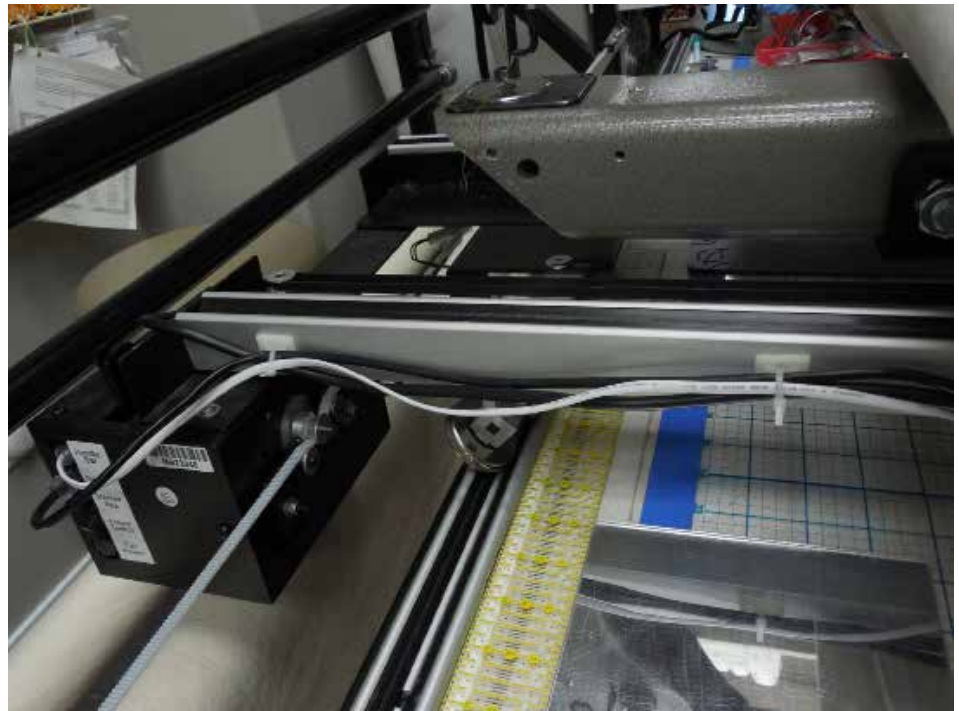
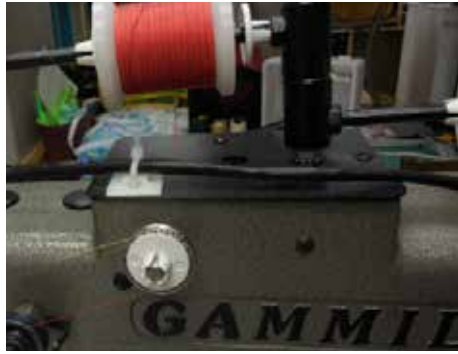

Rear Handle Bar Wires

If you have a QuiltEZ upgraded Stitch Regulator, then this Rear Handle Bar Wires section does not apply. Continue to page 20.

- 1** Remove the rear handle bar button and detach the spades that connect to the button wires.



If metal prongs get stuck:

Remove the metal prong from the spade.

Reinsert metal prong into the button.



Quilt EZ Button Cables

Each button cable has a label indicating which button it should be used with. Start/Stop is to be used for the button that starts and stops the stitch regulator, and Needle Up is to be used for the button that positions the needle up or down.

- 1** Remove the rear handlebars and feed the QuiltEZ cable in from the bottom and up to the button.

Vision II instructions continue on page 19



- 2** Connect the two ends of the included QuiltEZ button cable into the metal spades of the button.

Connect the original button wires to the remaining end of the Quilt EZ cable.



- 3** Reinsert the newly wired button into the handle bar.

Repeat Steps 1-3 for the remaining handle bar button.



For Vision II

- 1** The Vision II button has three prongs.

Plug one wire of the cable labeled “Needle Up” into the center prong, and plug the other to the prong under the “A” button.

Connect the original button wires to the remaining end of the Quilt EZ cable.



- 2** On the other handlebar connect one wire of the cable labeled “Start/Stop” into the center prong, and plug the other wire into the port under “D”

Connect the original button wires to the remaining end of the Quilt EZ cable.



- 3** Verify that the “A” button is programmed to be Needle Position, and that the “D” button is programmed to be Start/Stop Stitching in order for the machine to work properly.

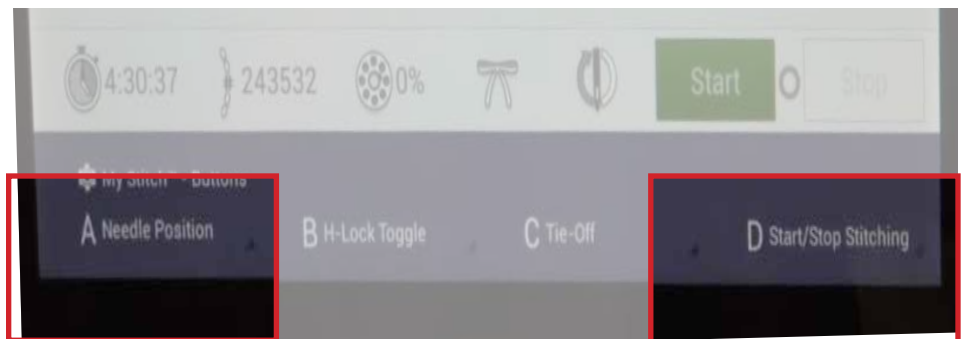

Connect Wires

For Perfect Stitch

Plug network cable into Stitcher Box port on Black Motor Box.

Plug remaining end of cable into the robotics port of the Perfect Stitch PCB box.

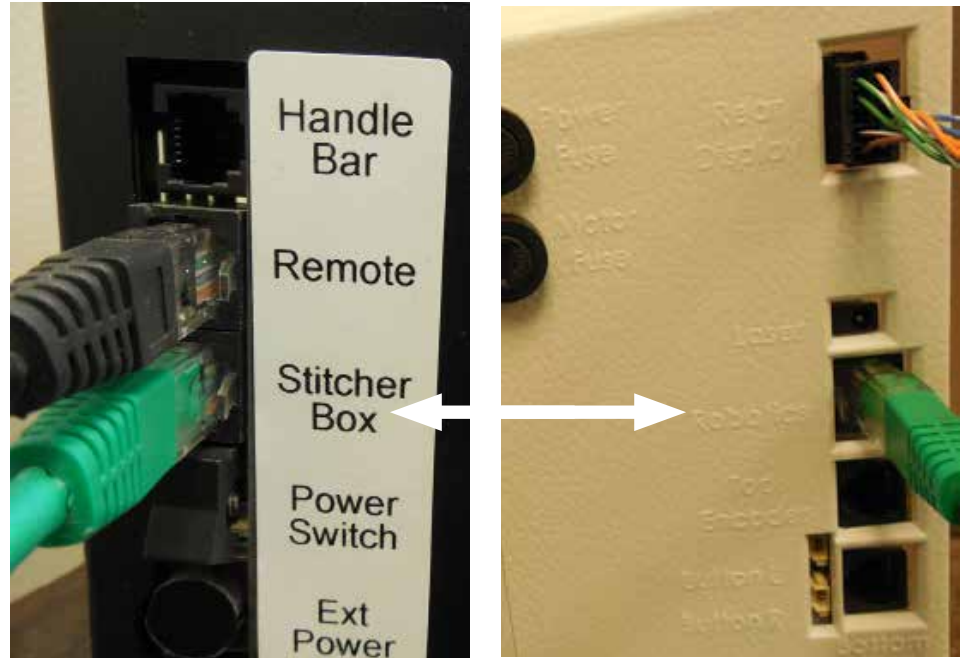

For Non-Perfect Stitch

Plug the remaining end of the Handle Bar Wires into the Handle Bar port.

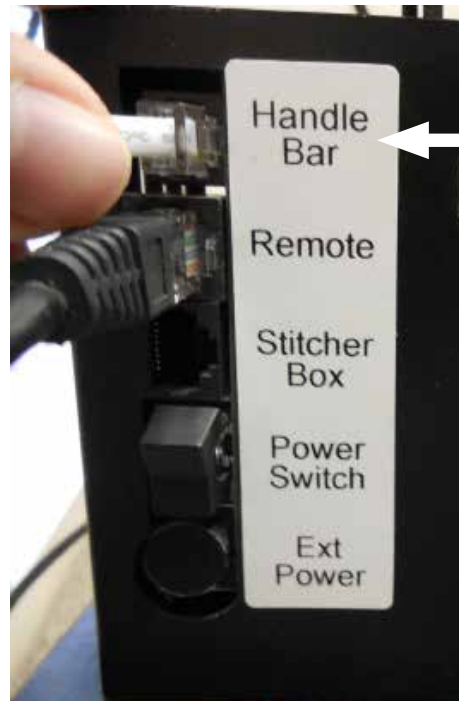

Set Machine Type

- 1 Power on the display, go to Setup > Advanced and set the machine type to Gammill.

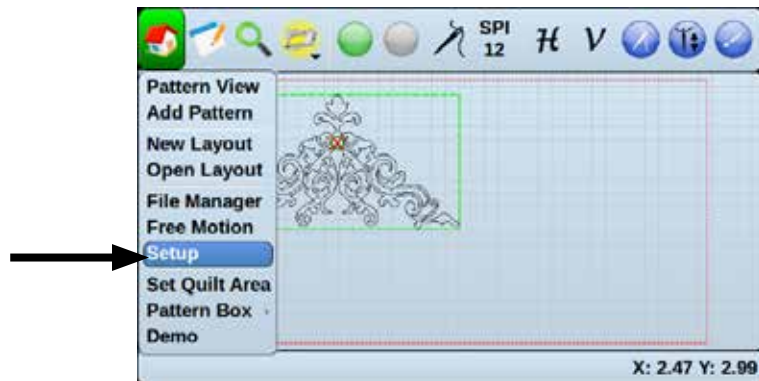

Check Belt Tension

- 1 A correctly tensioned belt has about a 1/2" of play with the motor box in the center.

Appendix A - How to use Belt Clamps

A belt clamp consists of two clamps and two screws.

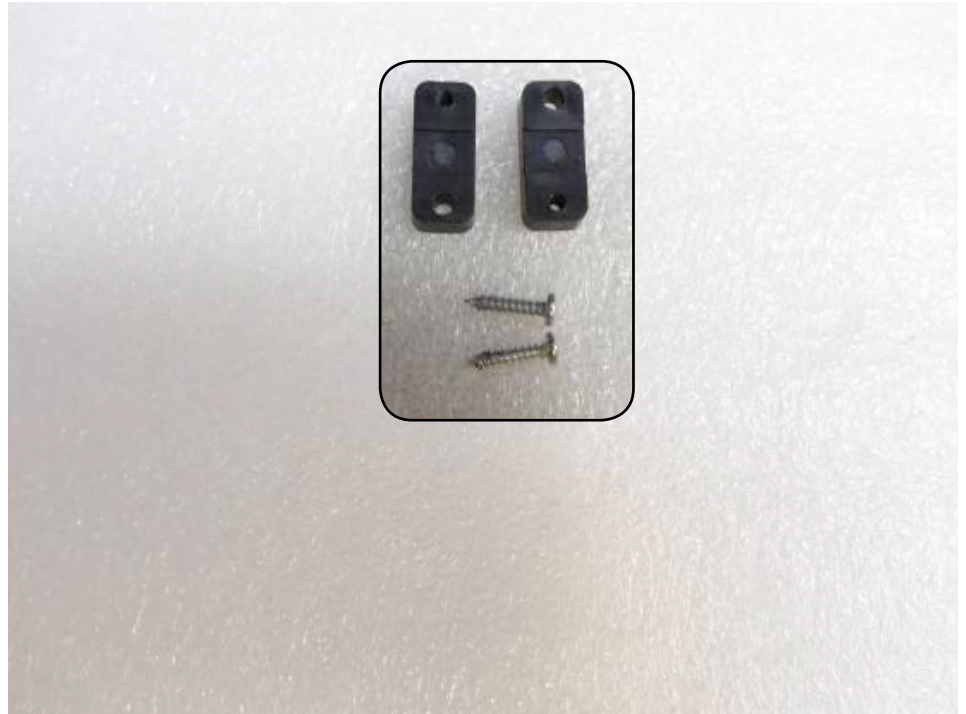

- 1** Using a Phillips screwdriver, insert each screw on opposite sides of the clamps and tighten halfway.

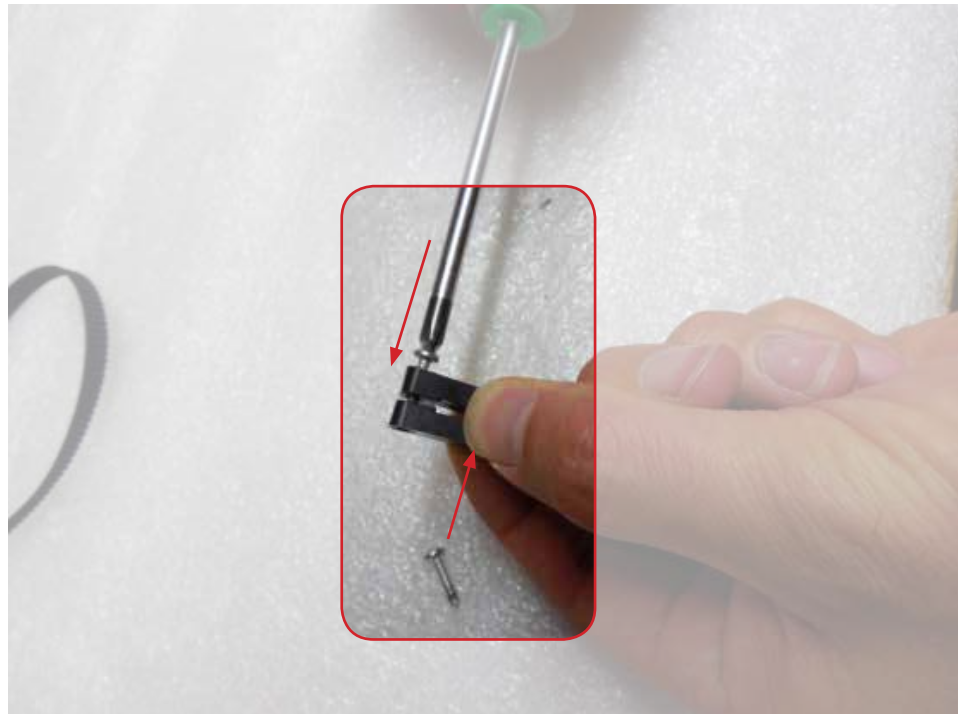

- 2** Thread the belt between the clamps, loop it around and reinsert it between the clamps.



- 3** Align the belt teeth, then finish tightening the clamps.



Appendix B- Additional help

Installing cables

Please refer to the Connecting Robot to Quilt Machine instruction set for help installing cables.

Power on the robotics

Use the power switch located on the side of the motor box with the ports to power the motor box off and on.

Disengage belts for free motion

In order to use free motion with the butler connected the belts will need to be disengaged.

To disengage the x-belt, move the locking lever away from the edge of the motor-box.

To disengage the y-belt, loosen the wing-nut on the carriage bracket.

You can now use free motion quilting.





Still need help?

Visit support.quiltez.com for
tutorial videos and additional
help documentation