

Quilt EZ *Perfect Stitch*

Machine Upgrade

Tin Lizzie 18 (Ribbon Cable) Assembly Instructions

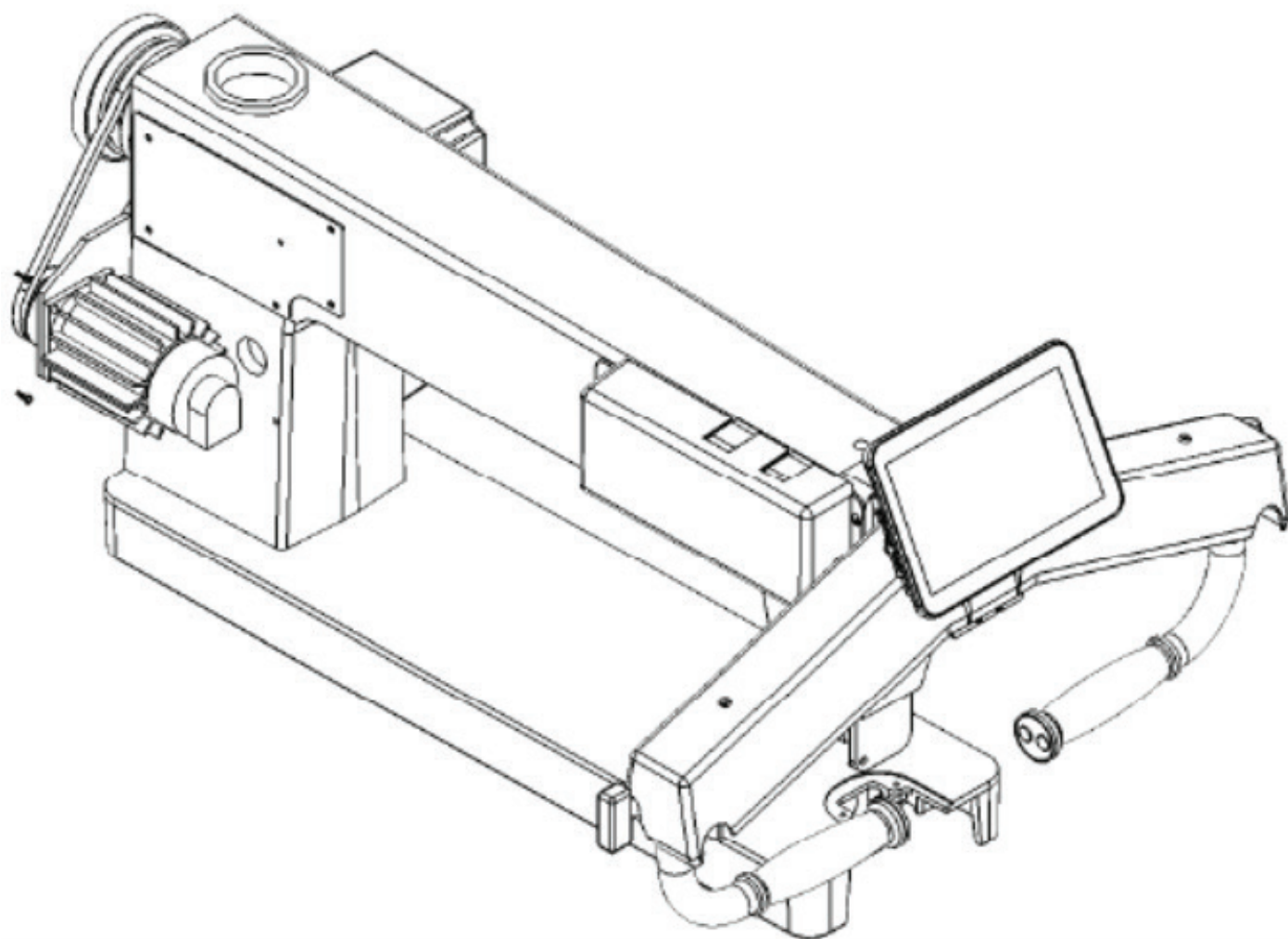

TABLE OF CONTENTS

Aides

- 3 Before You Begin
- 4 Tools
- 5 Perfect Stitch Parts

2

- 12 **Modify the Machine**
- 12 Prepare Drill Templates
- 12 Front Display
- 13 Control Box
- 14 Rear Display
- 15 Rear Power Supply
- 16 Motor

1

- 6 **Disassemble the Machine**
- 6 Remove the Handle Bars, Mount, PCB box
- 8 Remove Hand Wheel Cover
- 8 Remove the Motor Belt
- 9 Remove the Motor
- 9 Remove the Rocker Arm Covers
- 10 Remove the Handwheel
- 11 Remove the Faceplate

3

- 16 **Reassemble the Machine**
- 16 Attach the Faceplate
- 17 Attach Handlebars
- 18 Attach Android Display
- 19 Attach Linux Display
- 20 Feed Handlebar wires
- 21 Attach the Motor
- 22 Mount the Index Sensor
- 24 Attach the Control Box
- 26 Attach the Handwheel
- 27 Attach the Motor Belt
- 27 Attach the Rear Display
- 28 Attach the Rear Handlebars
- 29 Plug in Rear Handlebars
- 29 Attach Rear Access Cover
- 30 Attach Rocker Arm Cover
- 31 If Faceplate has no Hole

Before You Begin

Test the Machine

Before installing the upgrade, make sure that the machine is fully operational. Do not remove any electronics until the machine has been tested.

Determine Pulley Size

To get the correct ratio you will need to make sure that you install the correct size motor pulley.

Measure the machine pulley from end to end.

Divide that measurement by 1.5

The divided number translates to the ratio and corresponding size of pulley. This number is unlikely to be a whole number, round up or down to the nearest whole number.

Use this rounded number to choose the correct pulley size. The pulley diameter should equal the rounded number.

Pulley Sizes

1"

1 1/2"

2"

3"

AIDES

Tools

- Power drill
- Saftey glasses
- Hex key set
- Hammer
- Punch
- Electrical tape
- Hack saw
- Wrench or Socket set
- Clear or masking tape
- #1 Phillips screwdriver
- #2 Phillips screwdriver
- Flat head screwdriver
- #30 drill bit
- #29 drill bit
- #25 drill bit
- #7 drill bit
- 3/4" drill bit
- Tap wrench
- #1 4/20 tap
- #8-32 tap
- #10-24 tap
- Tapping oil

Perfect Stitch Parts

- (1) Touch screen display either:
Android 10" [106AA009]
Android 7" [106AA015A-7]
Linux 7" [110EA164A-PS]
- (1) Handlebar assembly
[106MA002A-Tan]
- (1) PerfectStitch PCB control box
[112EW001A-Black]
- (1) 180W Motor [105EW57400-AMP]
- (2) Rear handlebar assemblies
[105AW001A-Upgrade White]
- (1) Motor pulley V belt [AB172]
- (1) V belt 2L140 [P-UNI-BLT-3]
- (1) Rear display [105AW010A-
Generic]
- (1) PerfectStitch motor
[105EW57400-AMP]
- (1) Encoder assembly set
[130AA007A]
- (1) Continuous handlebar cable
[105AW005B]
- (1) 9 pin extension [114EW008A]
- (1) 10 pin extension [114EW007A]
- 110v power cable [AB178]
- (2) Motor heat sink [AB173]
- (1) Magnetic index assembly [Q-E-UNI-
PER-MAG-1]
- (1) Magnetic index collar [Q-E-UNI-
MAG-1]
- (10) 8-32 x 1/2" pan head screws [SCR PH
#8-32 X 0500 ZN]
- (2) 1/4-20 x 1/2" pan head screws [SCR PH
.25-20 X 0500 ZN]
- (7) 10-24 x 1/2" pan head screws [SCR PH
#10-20 X 0500 ZN]
- (6) 10-24 K-lock nuts [LOCKNUT TOOTH
#10-24 ZN]
- (4) #10 flat washer [#10 SAE Washer]

1 - DISASSEMBLE THE MACHINE

Remove the Handlebars, Mount, and PCB box

1. Loosen the knob and remove the handlebars.

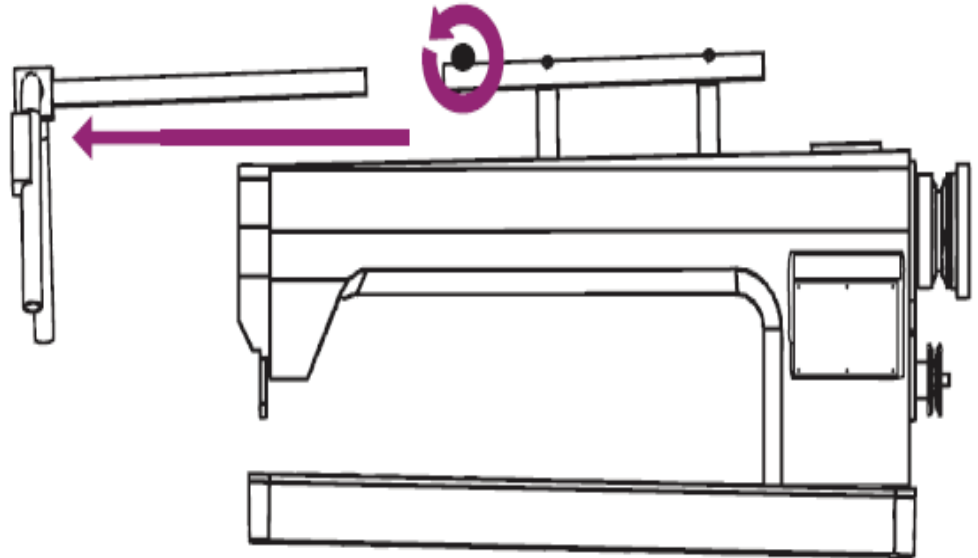

2. Unscrew the top two screws and remove the mount.

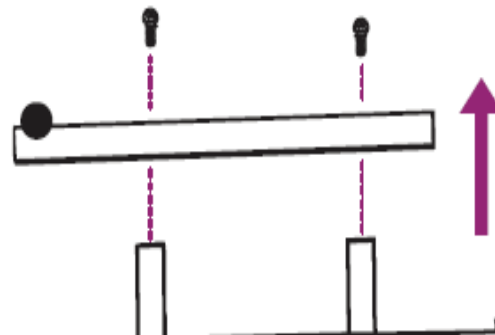

3. Unscrew the six screws attaching the PCB box face. Remove the face and set it aside.

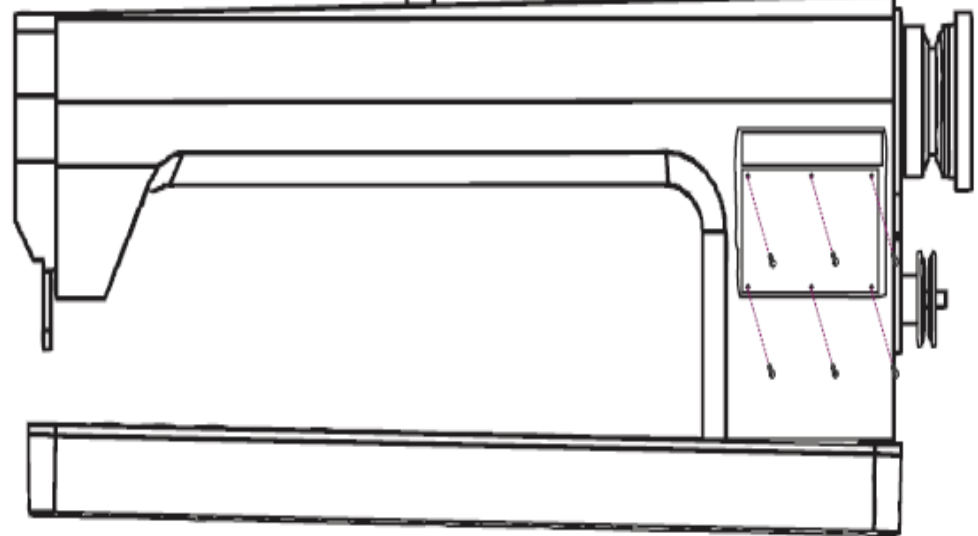

4. Remove the four screws on the right edge of the PCB

5. Pull the first board back to reveal the second board

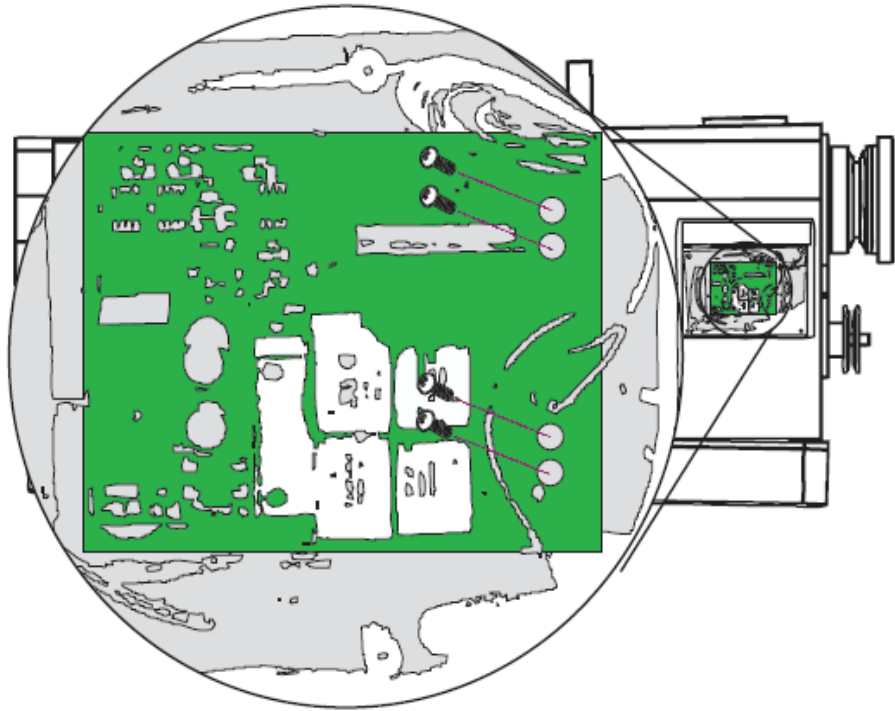

6. Loosen the two screws on the right of the second board and remove the ground wires underneath.

7. Using a hex key remove the two screws that attach to the aluminum frame.

8. Set the screws aside and remove the PCB from the frame.

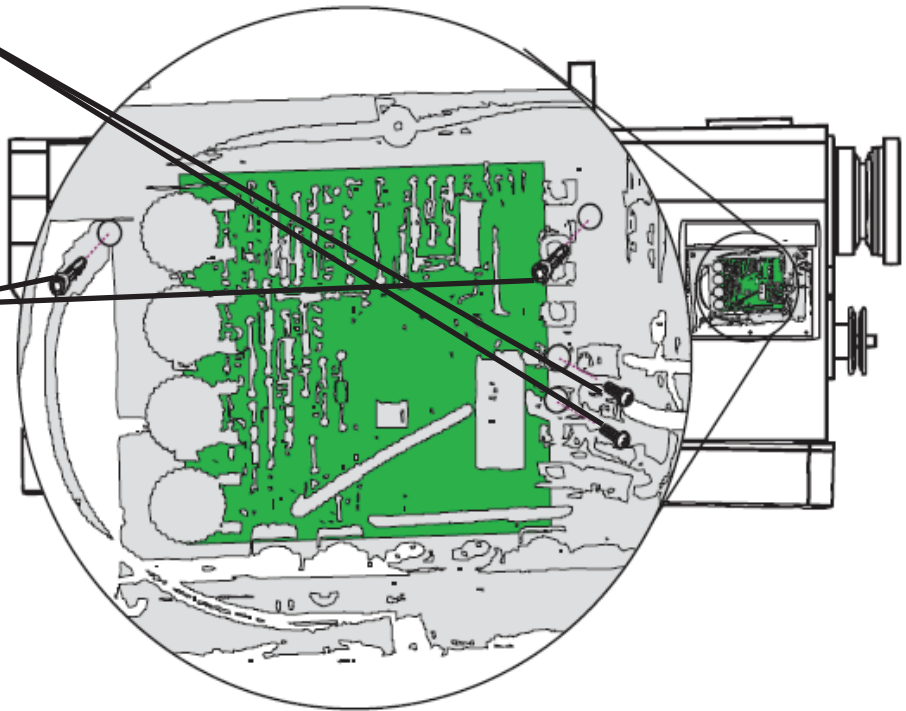

Remove the Handwheel Cover

1. Unscrew the three screws from the belt cover. Remove the cover and set aside with the screws for later use.

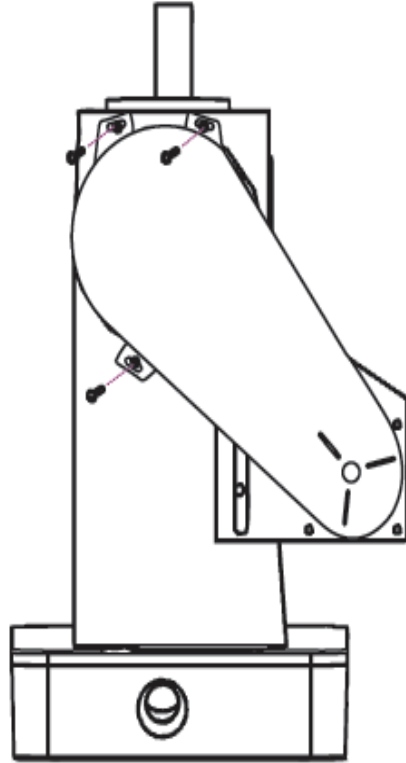

Remove the Motor Belt

1. Use a hex key to loosen (Do not remove) the motor adjustment bolts.
2. Raise the motor bracket, remove the belt, and then lower the motor back in place.

loosen motor adjustment bolts

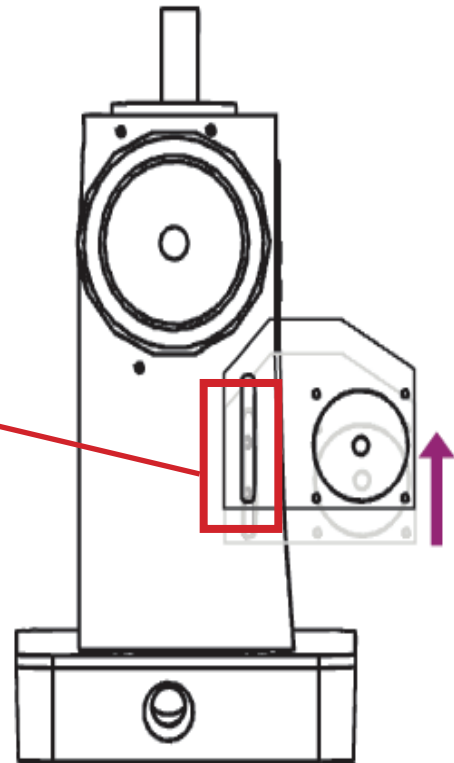

Remove the Motor

1. Hold on to the motor with one hand, and remove the motor adjustment bolts.
2. Remove the motor and motor cable from the machine. Set aside for later use.

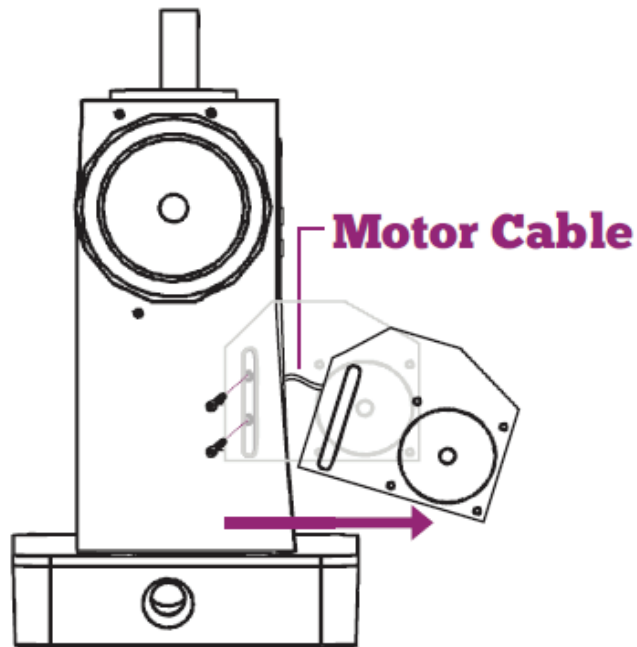

Remove the Rocker Arm Covers

1. Remove the five screws from the rear access cover and remove the cover. Set aside for later use.
2. Remove the four screws from the rocker arm access cover and remove the cover. Set aside for later use.

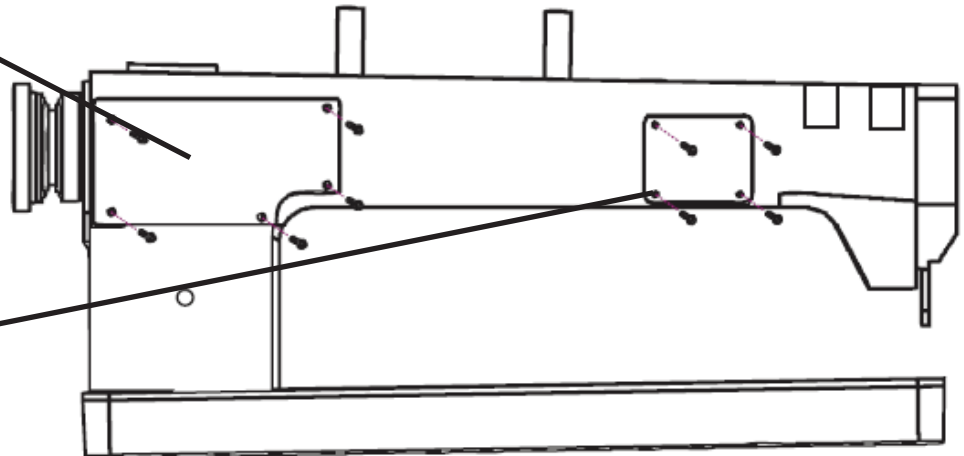

Remove the Handwheel

1. Use a Phillips head screwdriver to remove the two screws securing the handwheel to the shaft

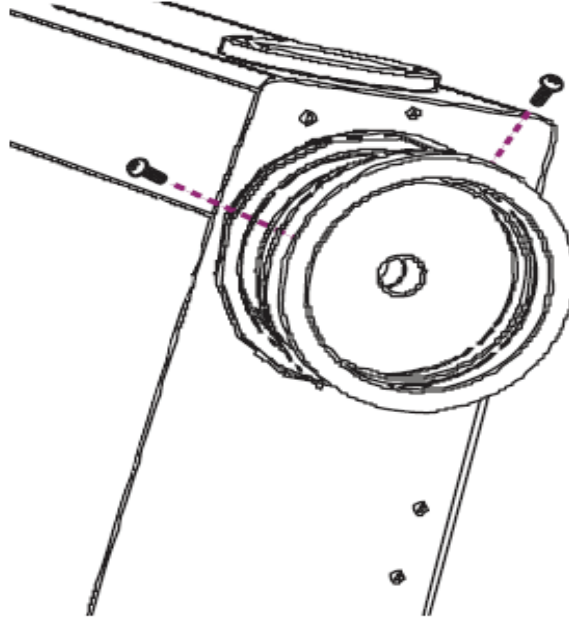

2. Slide the handwheel off the shaft and set aside with the screws for later use.

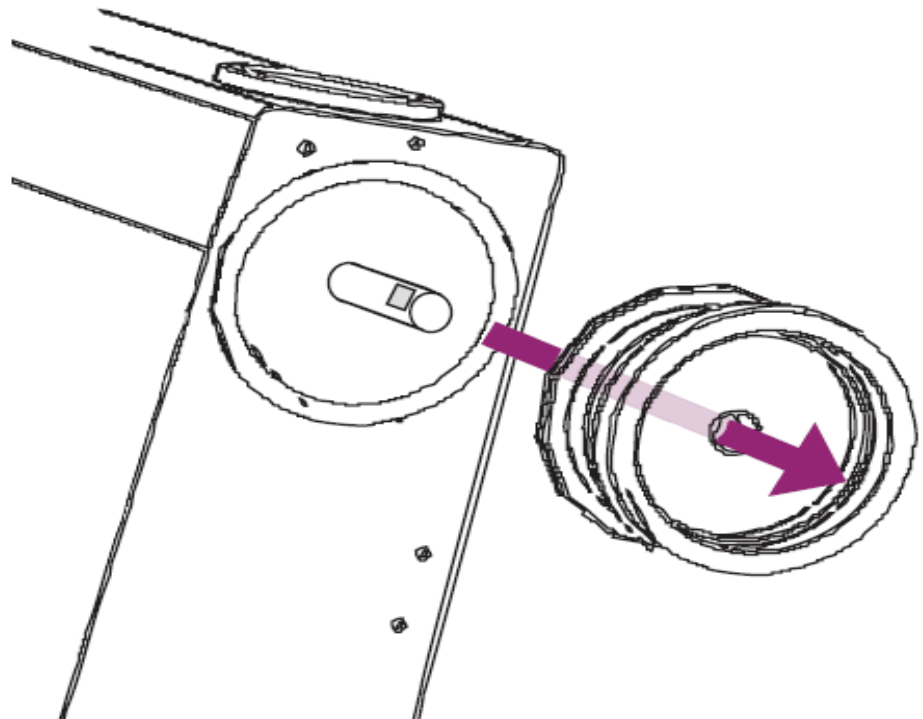

Remove the Faceplate

1. Use the flat head screwdriver to remove the three screws attaching the faceplate. Set aside for later use.

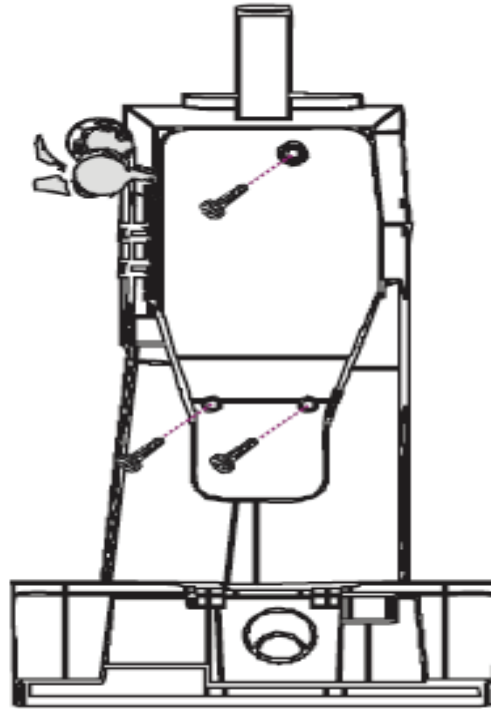

2 - MODIFY THE MACHINE

Prepare Templates

1. Cut out the templates included at the back of this manual. Cut each template along the dotted line.

Read the instructions listed on the template before drilling.



Front Display

1. Tape the front display template to the face plate of the machine.
2. Use a hammer and punch to mark the drill points.
3. Use the power drill and a #25 bit to drill the points.
4. Use a #10-24 tap on the drilled holes.

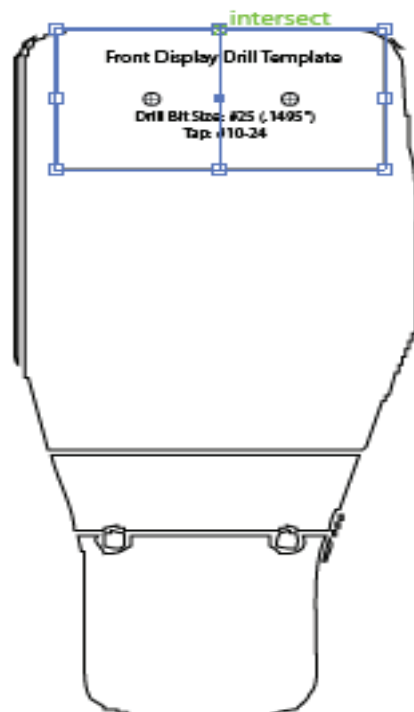

Control Box

1. Tape the control box template to the side of the machine. (Right from front.)
2. Use a hammer and punch to mark the drill points.
3. Use the power drill and a #29 bit to drill the points.
4. Use a #8-32 tap on the drilled holes.
5. The frame is thicker at the top right, and needs to be drilled 1/2"

Mark with tape 1/2" from the tip on the bit, and drill into the frame until the tape reaches

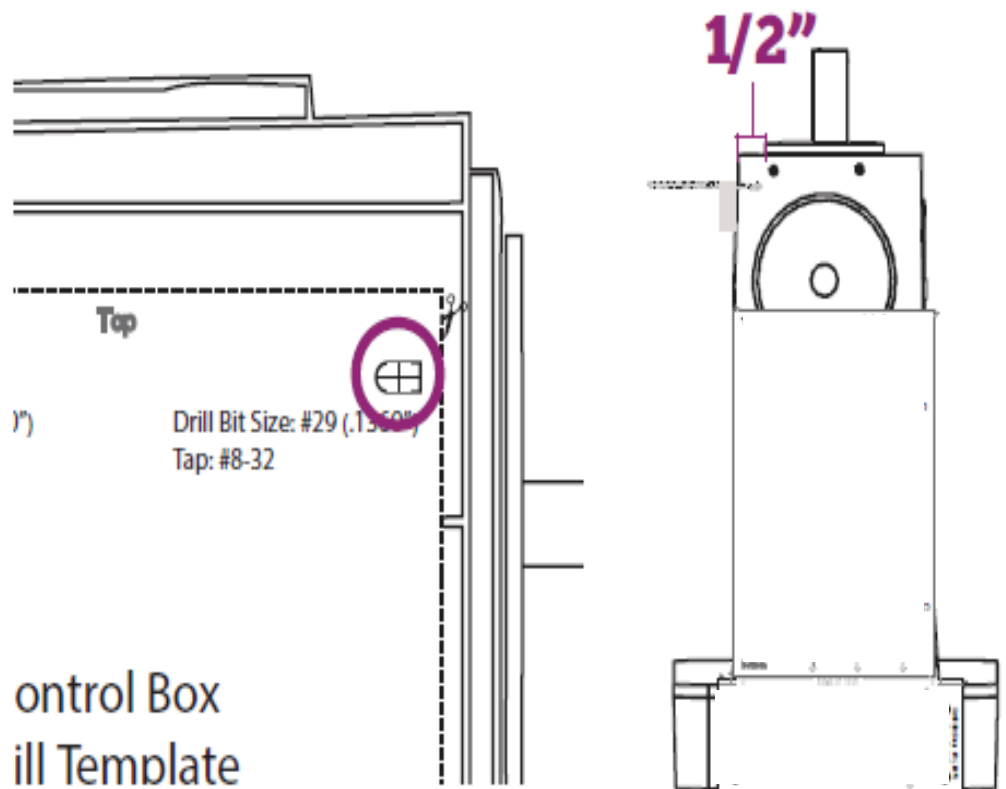
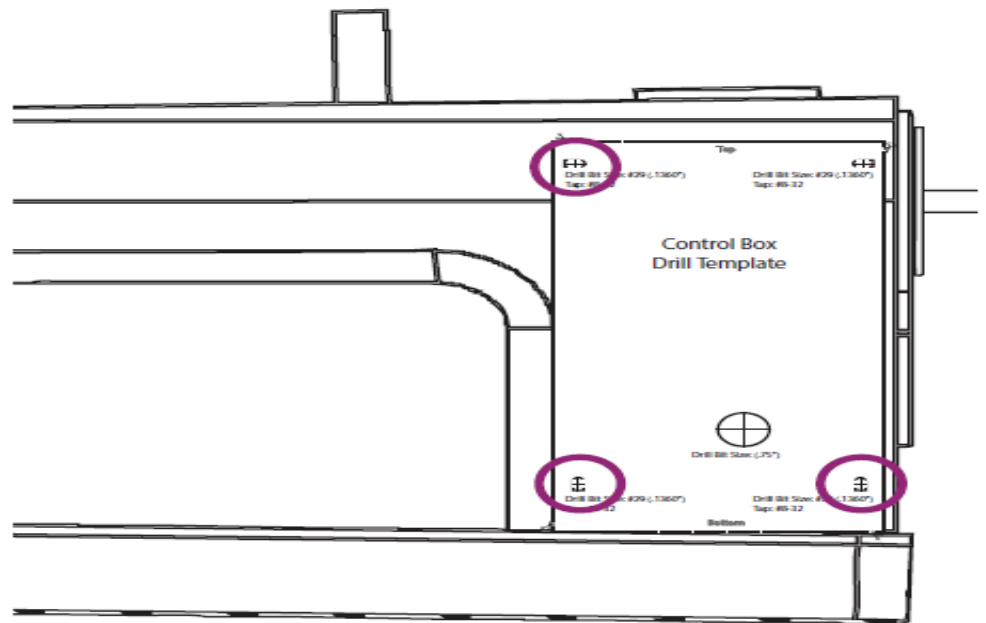

the frame.

6. Use the #29 drill to drill a pilot hole in the larger drill point

Then drill the point with a 3/4" bit.

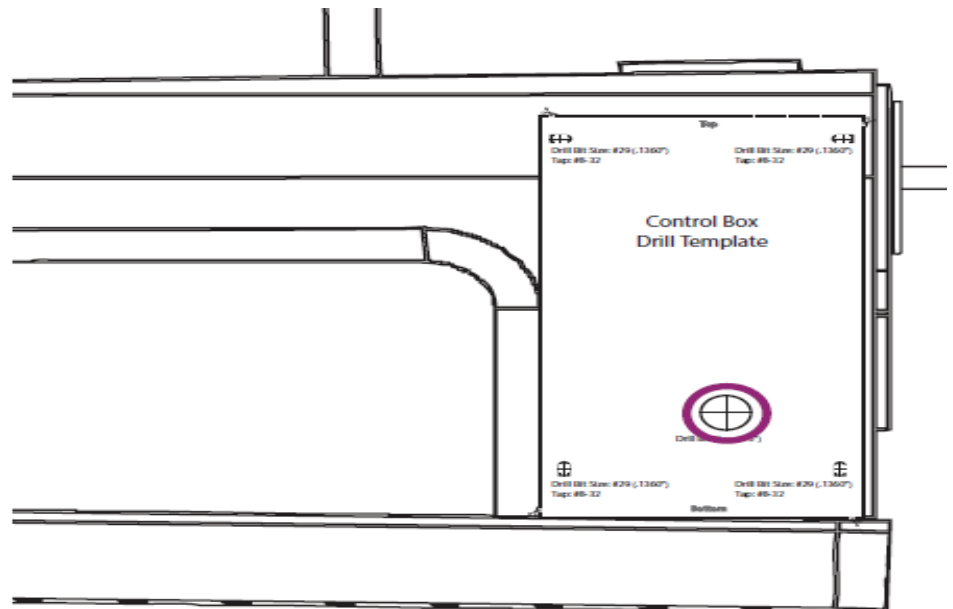

Rear Display

1. Tape the rear display template to the back base of the machine.
2. Use a hammer and punch to mark the drill points.
3. Use the power drill and a #29 bit to drill the two smaller points.
4. Use a #8-32 tap on the drilled holes.
5. Use a #7 bit to drill four larger points.
6. Tap drilled holes with a #1/4-20 tap

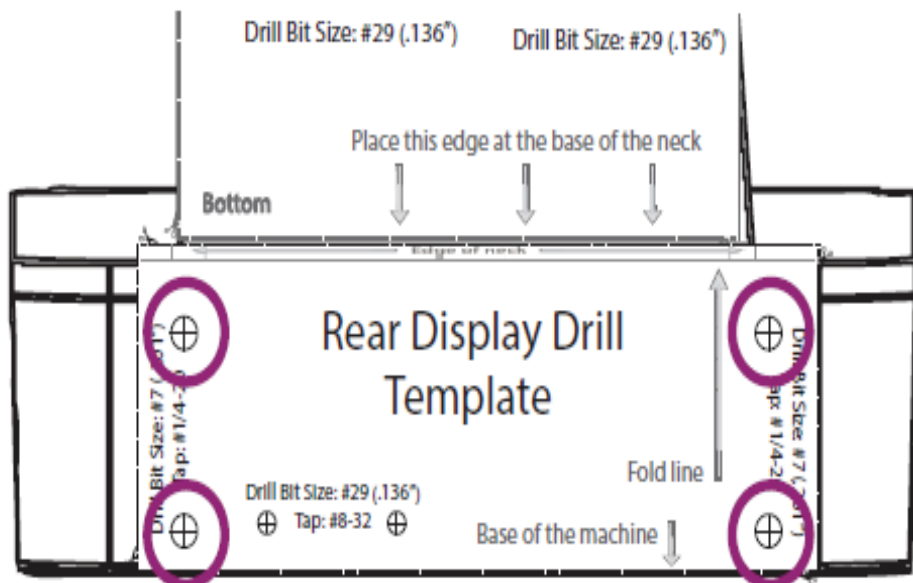
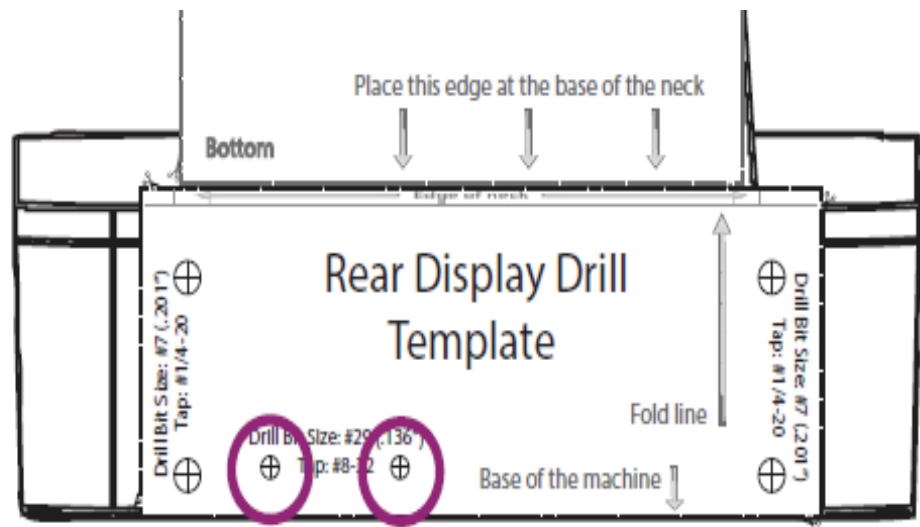

Rear Power Supply

1. Tape the rear power supply template to the back of the machine.
2. Use a hammer and punch to mark the drill points.
3. Use the power drill and a #29 bit to drill the four center points.

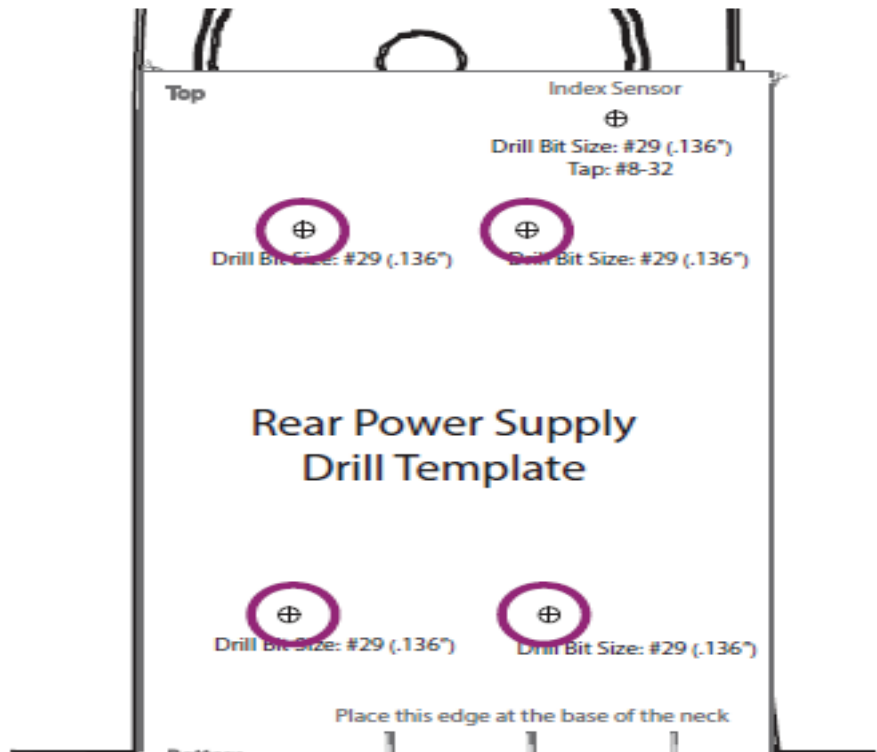

4. If there is not already a hole for the sensor, use a #29 bit to drill this point.
5. Tap the index sensor point with a #8-32 tap.

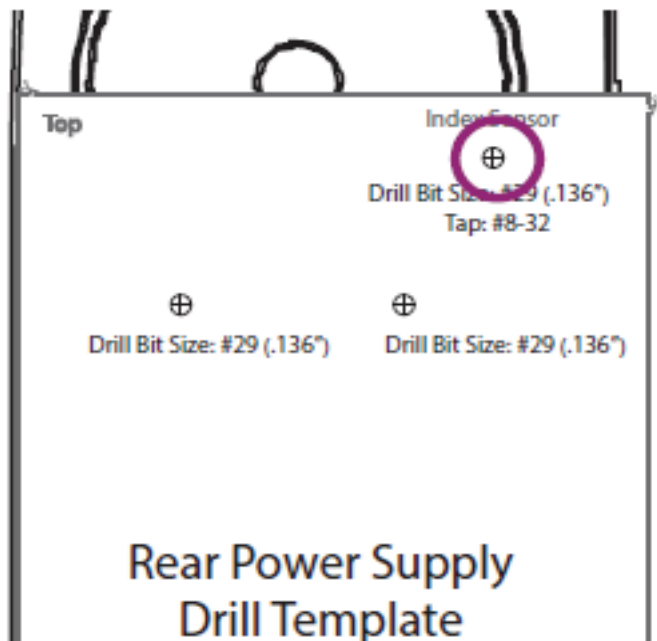

Motor

1. Tape the motor side template to the side of the machine. (Left from front.)
2. Use a #29 bit to drill a pilot hole through the frame.
3. Use a 3/4" bit and drill the point.

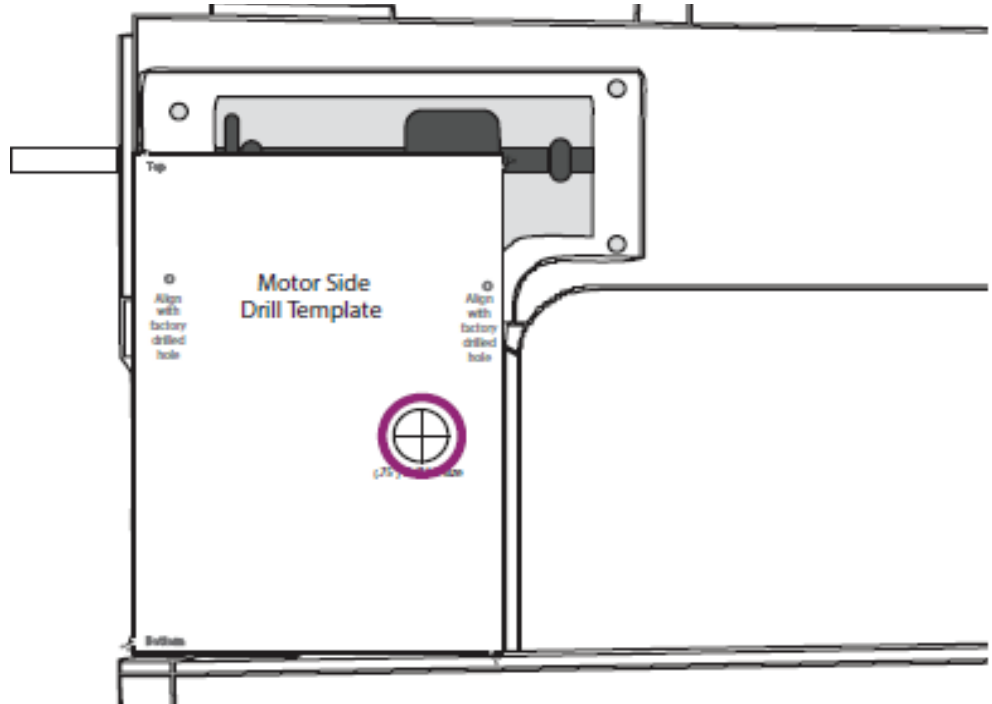

3 - REASSEMBLE THE MACHINE

Attach Faceplate

1. Insert two 10-24 x 1/2" screws into the drilled holes from the rear of the faceplate. Secure, but do not over tighten.

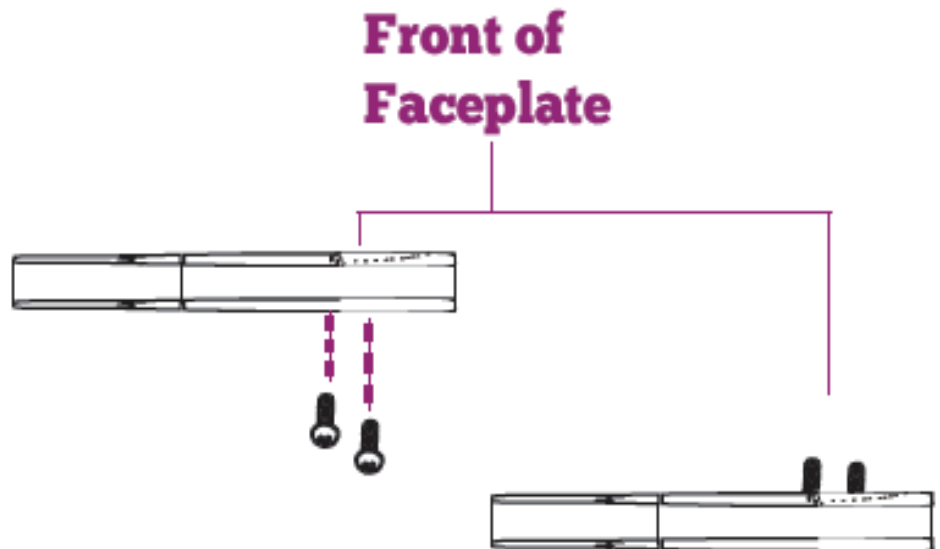

2. Reattach the faceplate with the three original screws.

The screws from step 1 should be facing out.

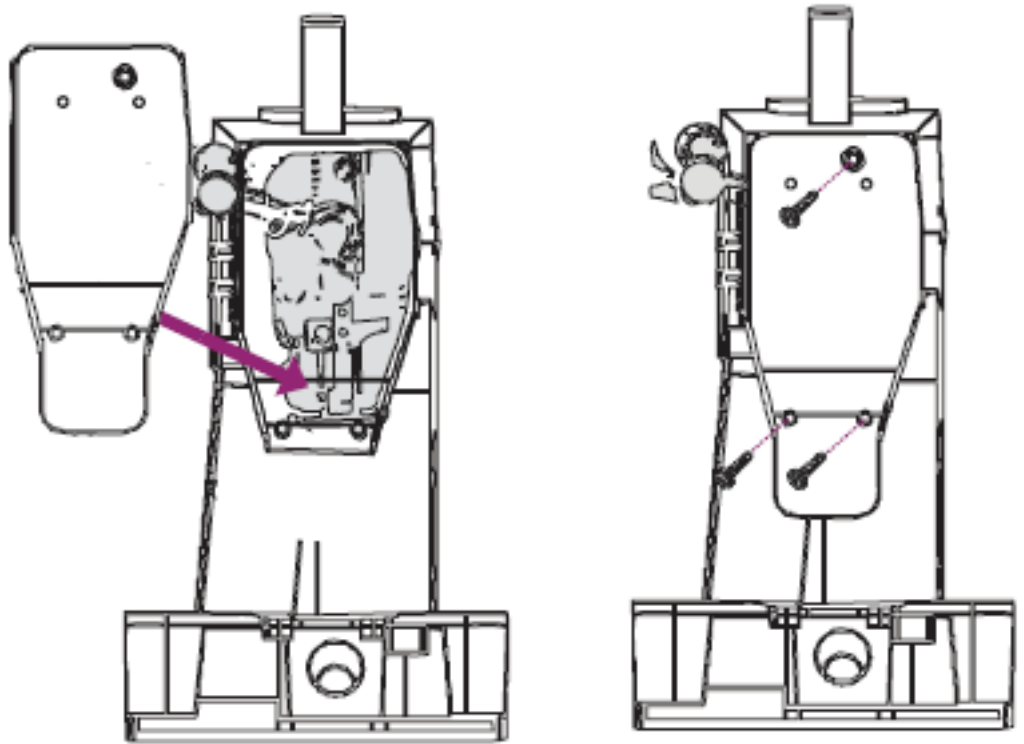

Attach Handlebars

1. Align the holes on the handlebar bracket with the two screws facing out on the faceplate.
2. Secure the handlebars with the provided nuts.

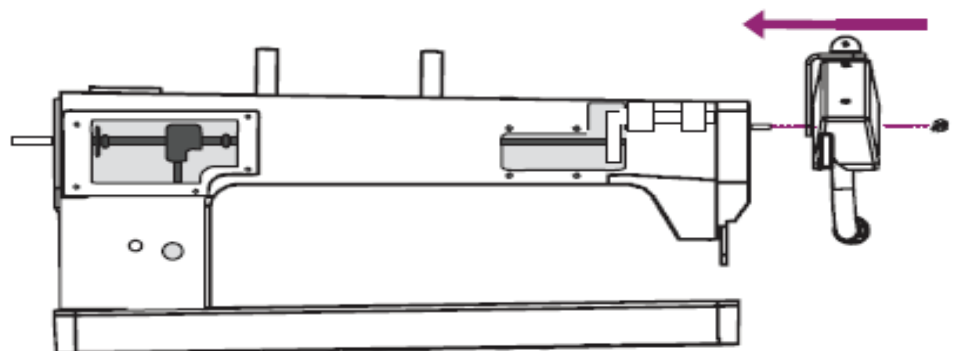
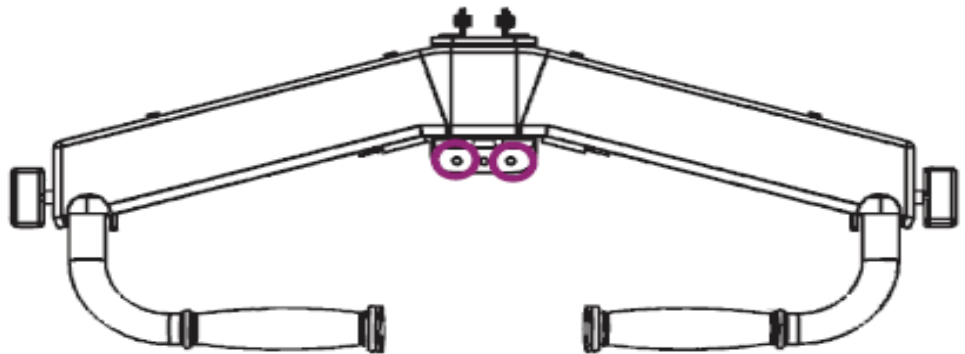

Attach Android Display

1. Remove the two screws from the top of the handlebars.
2. Attach the remote base brackets to the handle bar with the two provided screws and the two removed in step 1.
3. Mount the remote bracket to the remote bases with the white poly disc in between.
4. For further instruction on installing the 10" display, please refer to the *Installing/Troubleshooting your Android Tablet* guide.

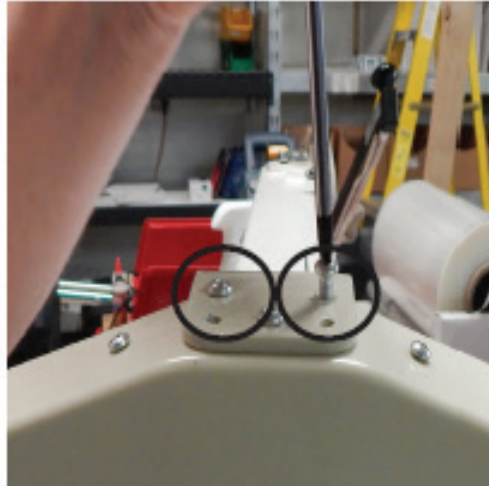

Attach Linux Display

1. Remove the two screws from the top of the handlebars.
2. Attach the remote base brackets to the handle bar with the two provided screws and the two removed in step 1.



3. Mount the remote bracket to the remote bases with the white poly disc in between.

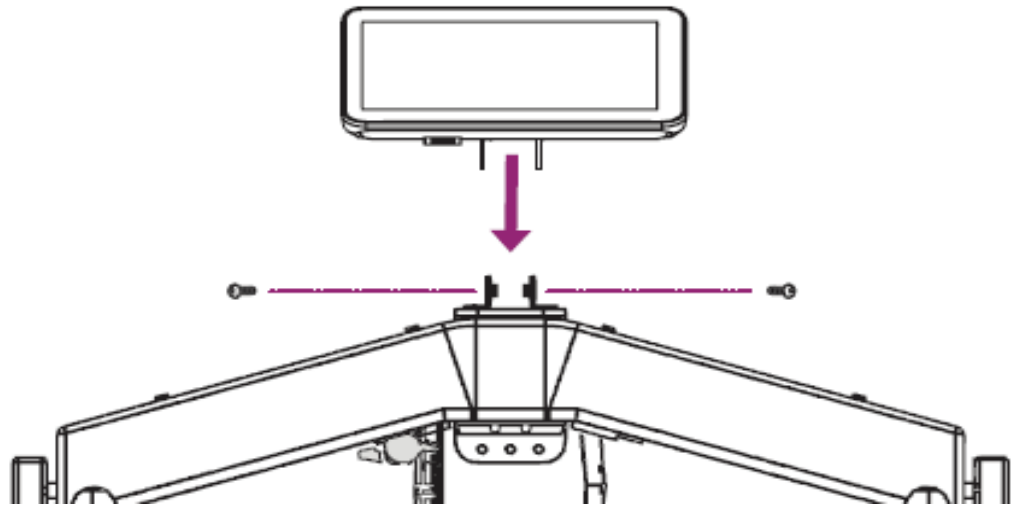

4. Connect the display cable to the display with the triangles facing forward.

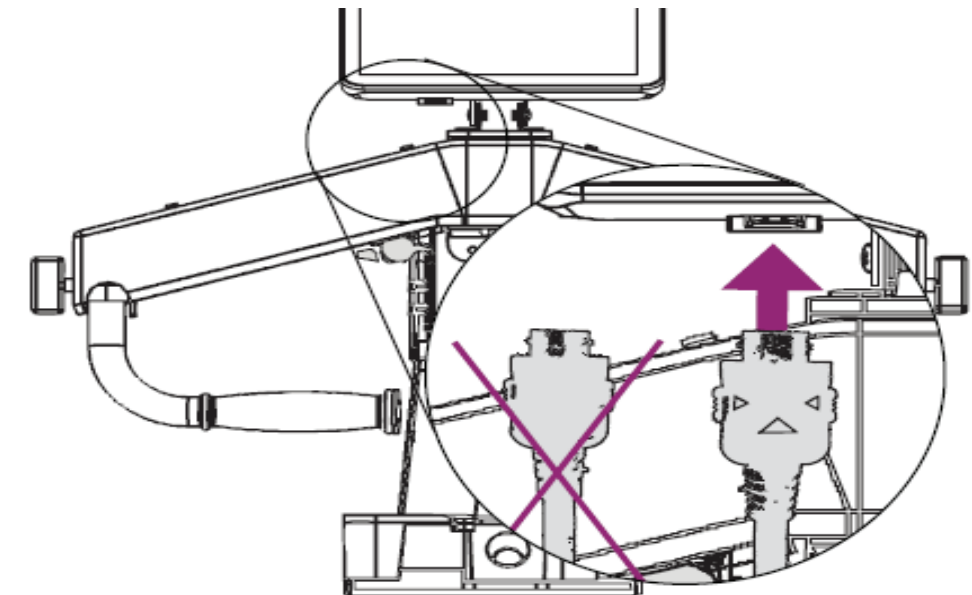

Feed Handlebar Wires

1. Feed the three wires coming from the handlebars through the machine to the rear.

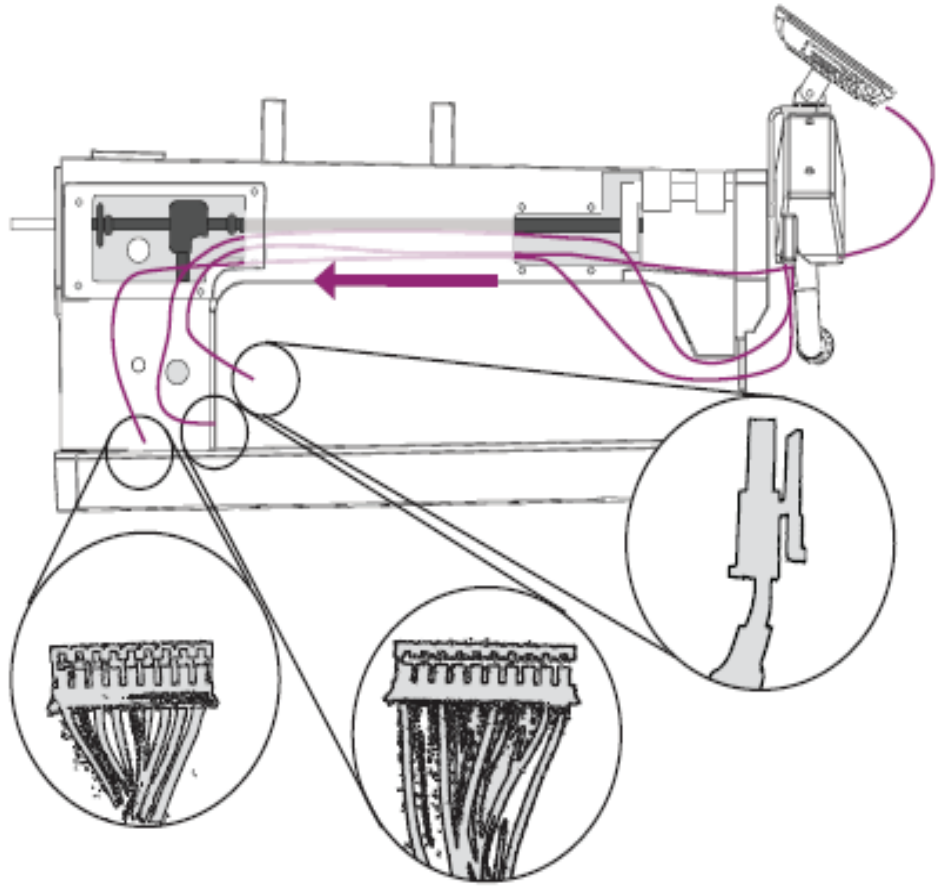

2. Make sure the cables are out of the way of any moving components.

3. Feed the wires through the hole on the control box side.

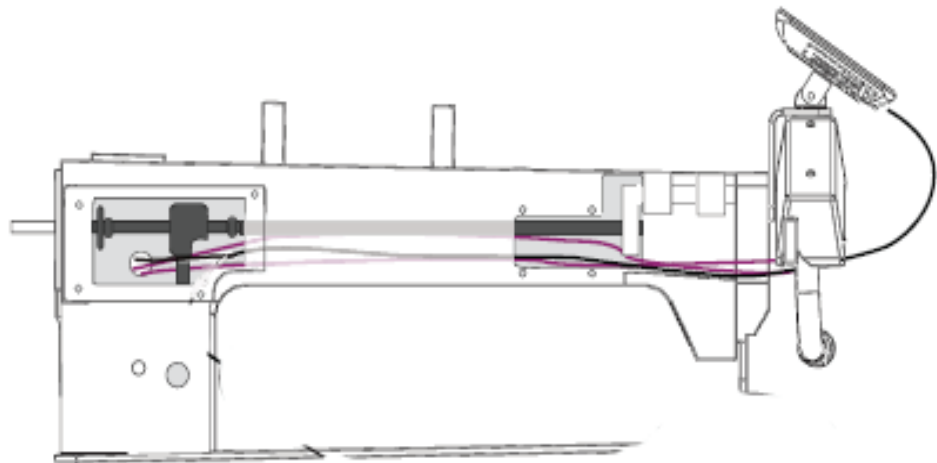

Attach the Motor

1. Feed the motor wires through the hole drilled for the motor.

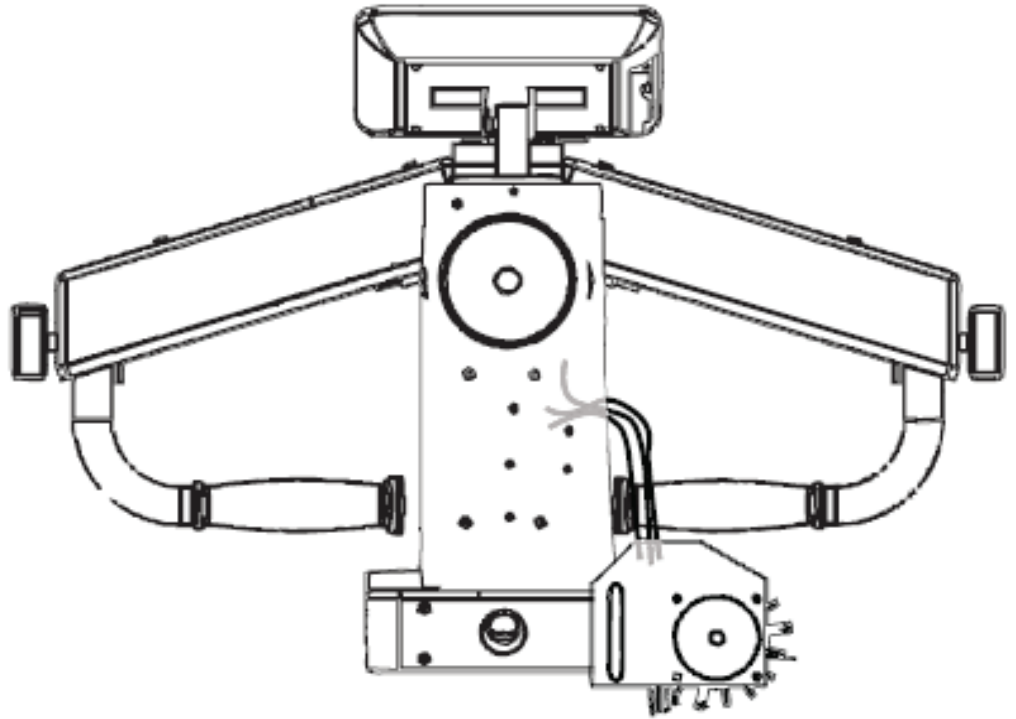

2. Position the Perfect-Stitch motor on the side of the machine, and attach it with the original motor adjustment screws.

3. Feed the wires through the lower hole on the control box side.

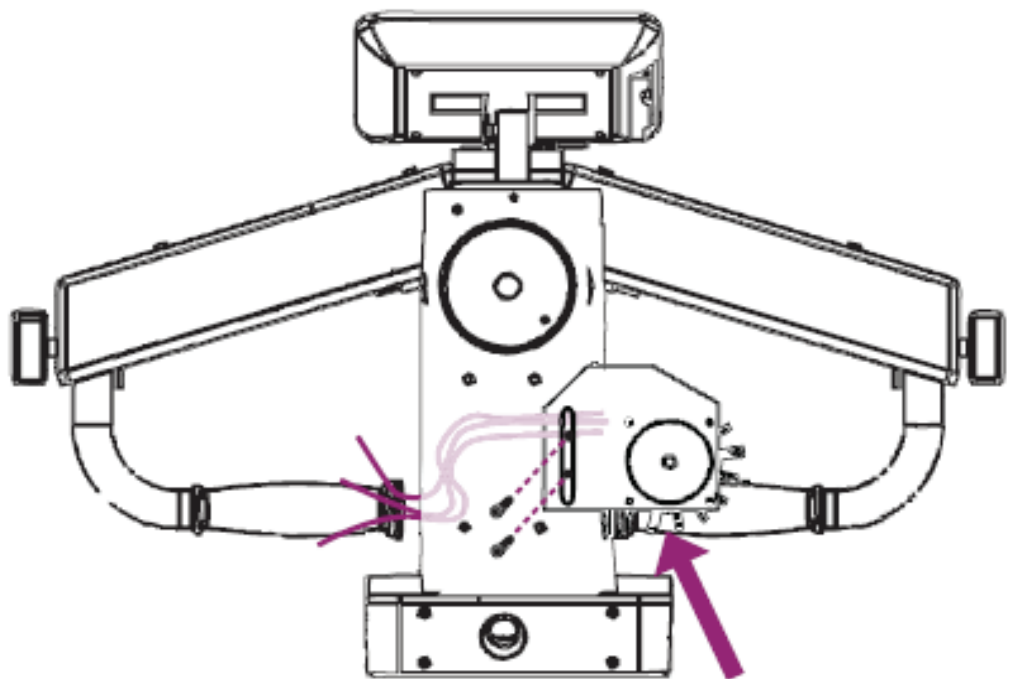

Mount the Index Sensor

1. Cut the sensor bracket approximately 1/2" on the slotted side.
2. Use the provided double sided tape to mount the sensor to the bracket.

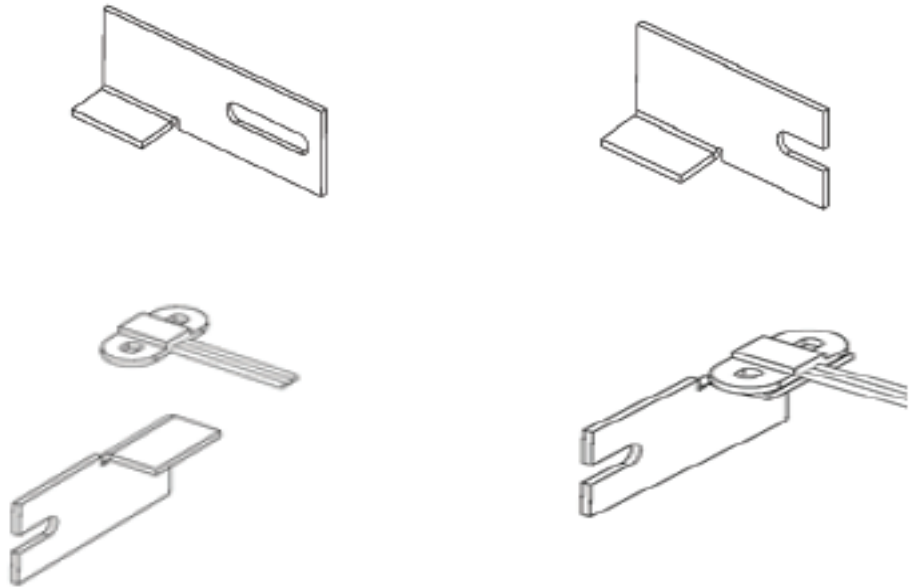

3. Remove the current index sensor. Save the screw for later use.

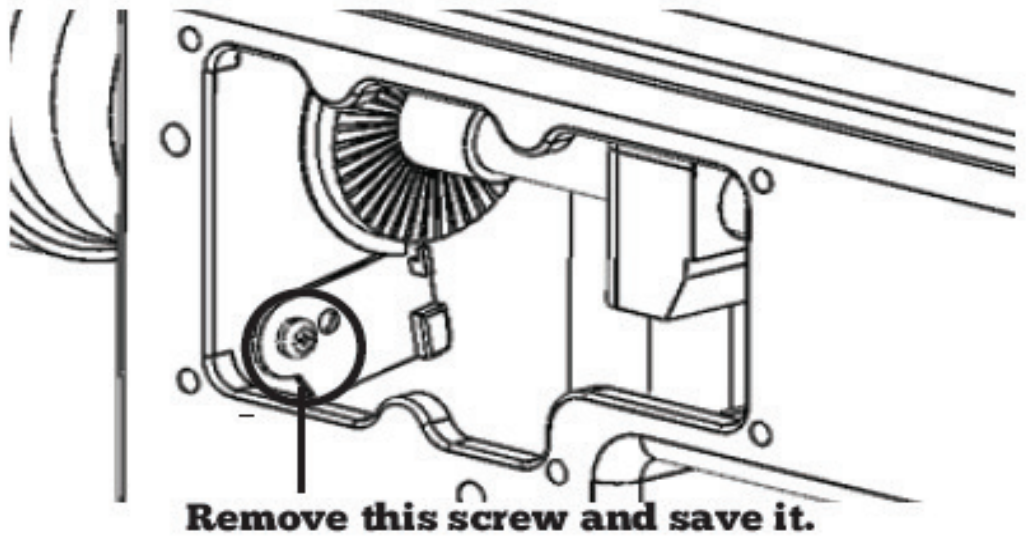

4. Install the magnetic index with the screw removed in step 3.

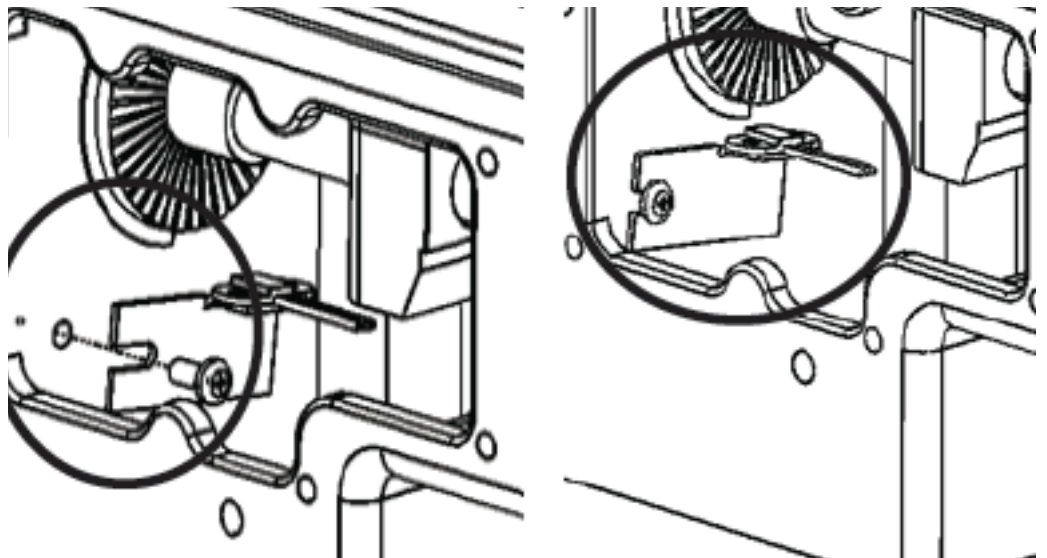

5. Remove the index flag by applying pressure toward the rear of the machine.

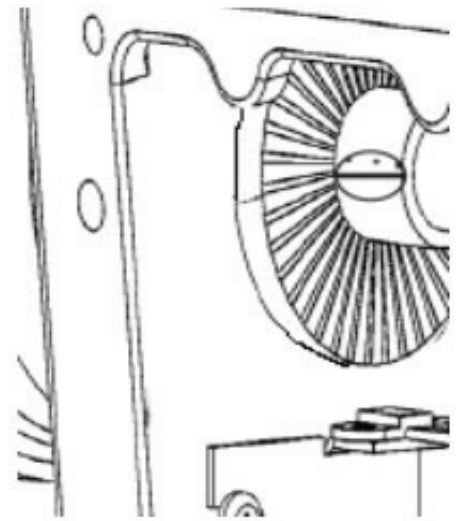
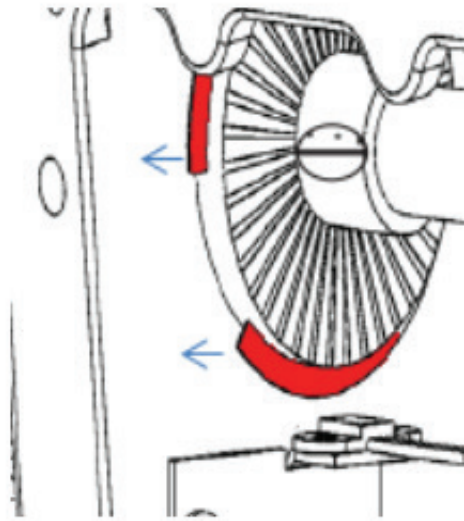

6. Use epoxy glue to mount the magnet on the outer edge of the index parallel to the inner set screw.

Place the magnet with the X facing out.

Inner set screw

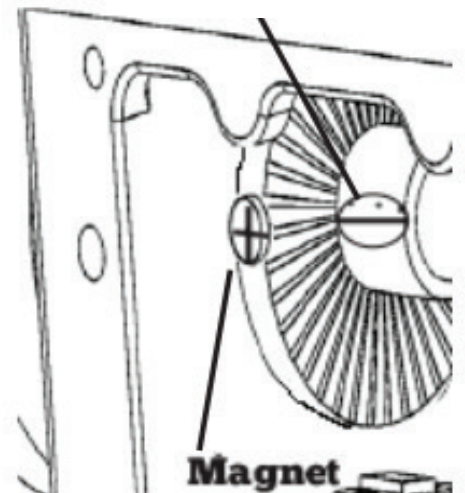
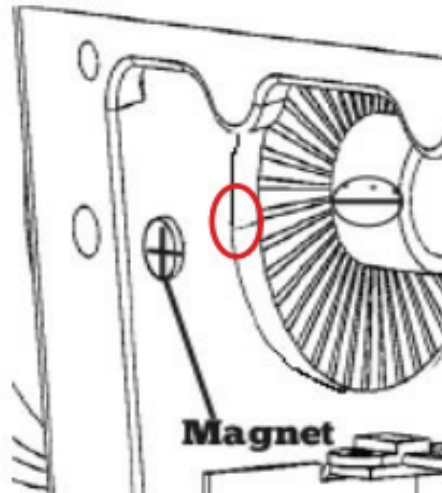

Loosen

7. Loosen the inner set screw, and spin the handwheel until the needle is in the up position.

Rotate the sleeve until the magnet is directly over the index sensor, then tighten the set screw. The magnet should set about 1/4" above the sensor.

Note: Do not move the sleeve left or right. If the magnet is not directly over the sensor use washers to space the sensor bracket until the sensor is beneath the magnet.

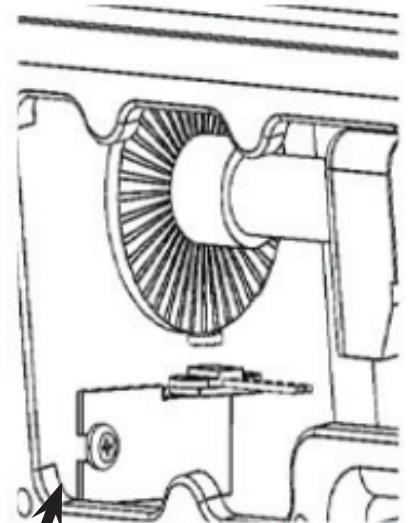
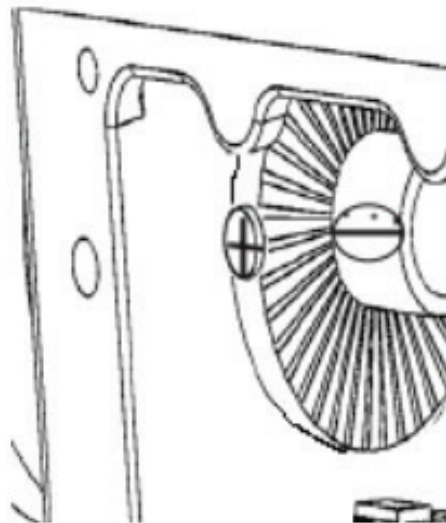

Apply washers as needed.

Attach the Control Box

1. Position the control box near the internal wires.

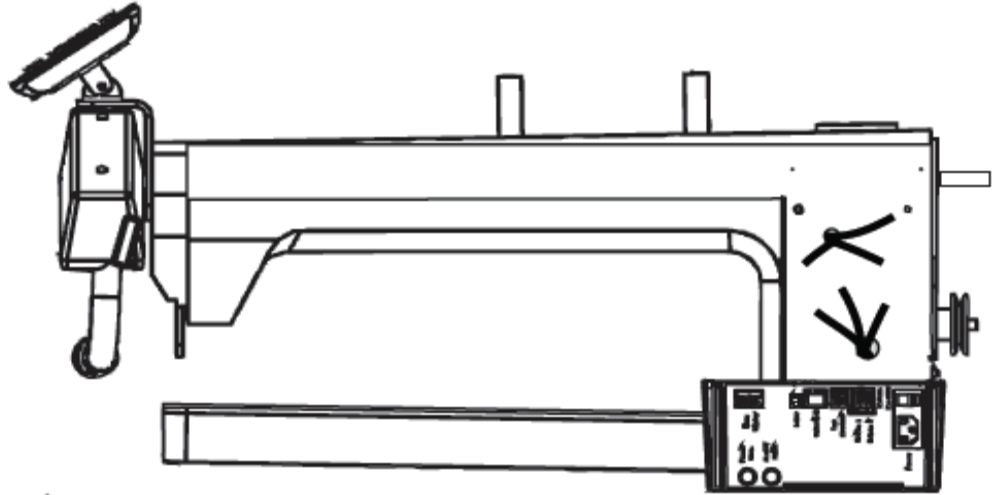

2. Connect the motor power wire to the port labeled UVW.
3. Connect the motor hall sensor wire into the wire into the Hall Sensor port.
4. Connect the motor wire to the Motor Encoder port.

*Note: Do **NOT** plug into the port labeled Index.*

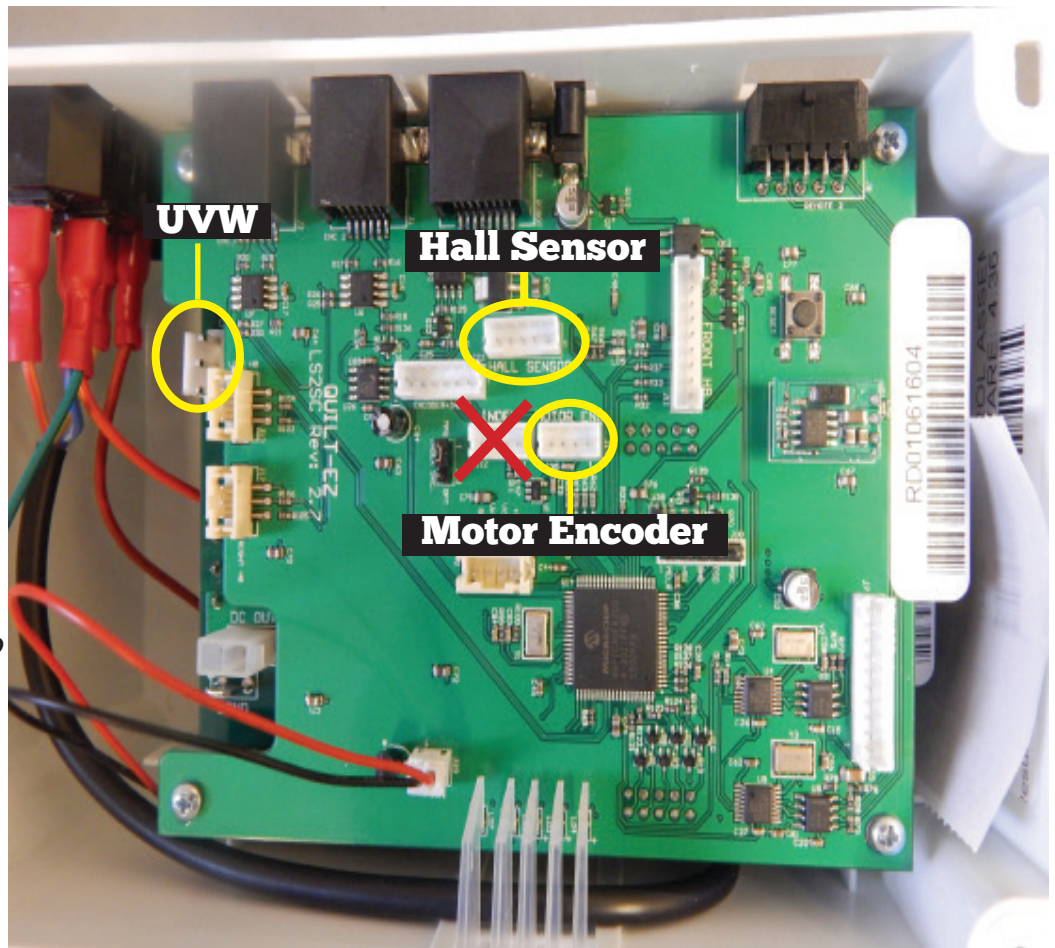

5. Connect the magnetic index sensor to the Magnetic Index port.
6. Connect the front handlebar wire to the Front HB port

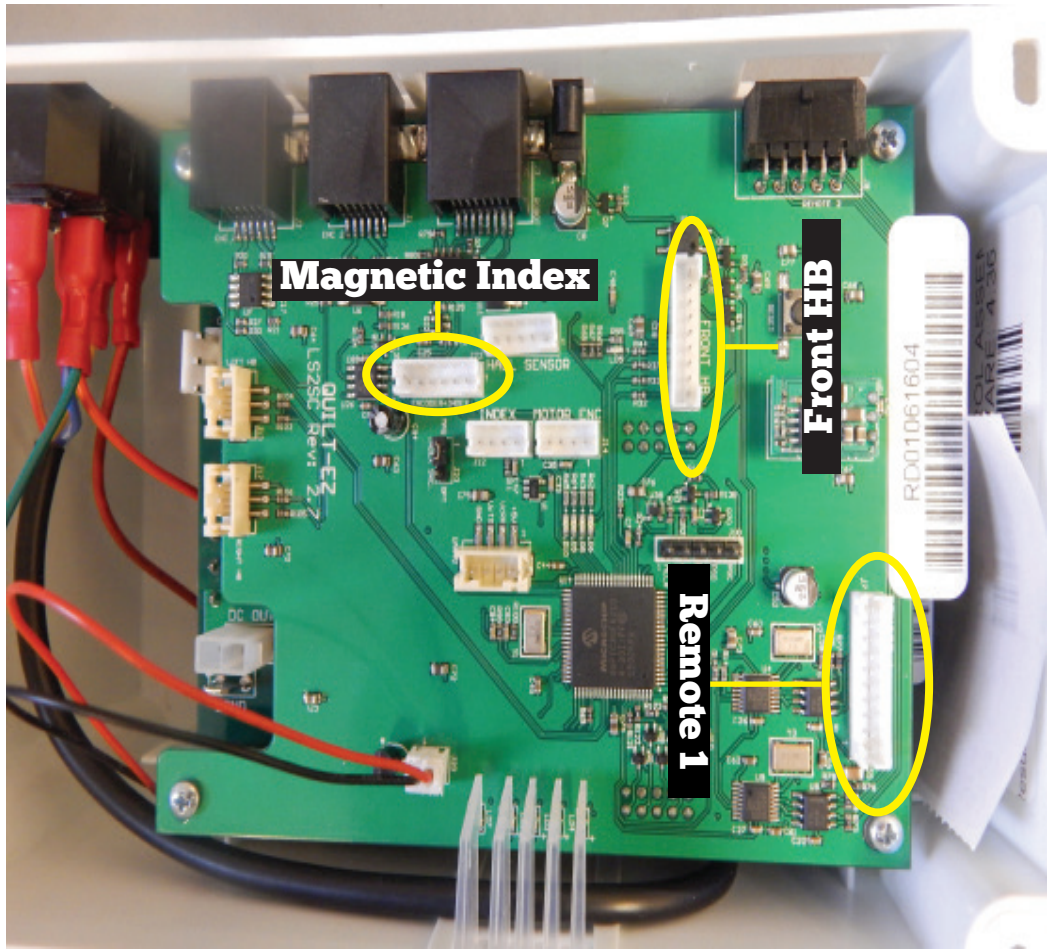

7. Attach the ground wire to the frame using the factory drilled hole and one of the original control box screws.

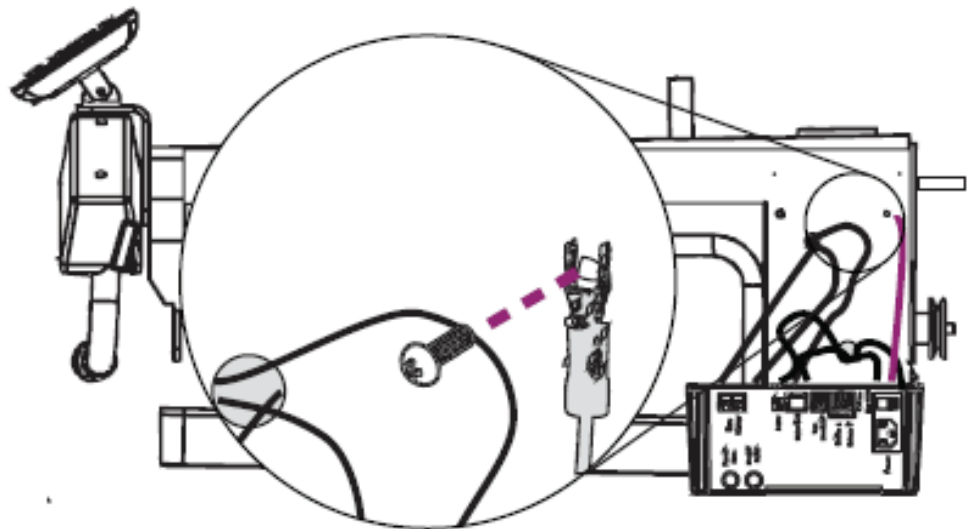

8. Mount the control box to the frame by fastening the four 8-32 x 1/2" screws to the drilled holes. Secure the bottom screws first, and then the top two.

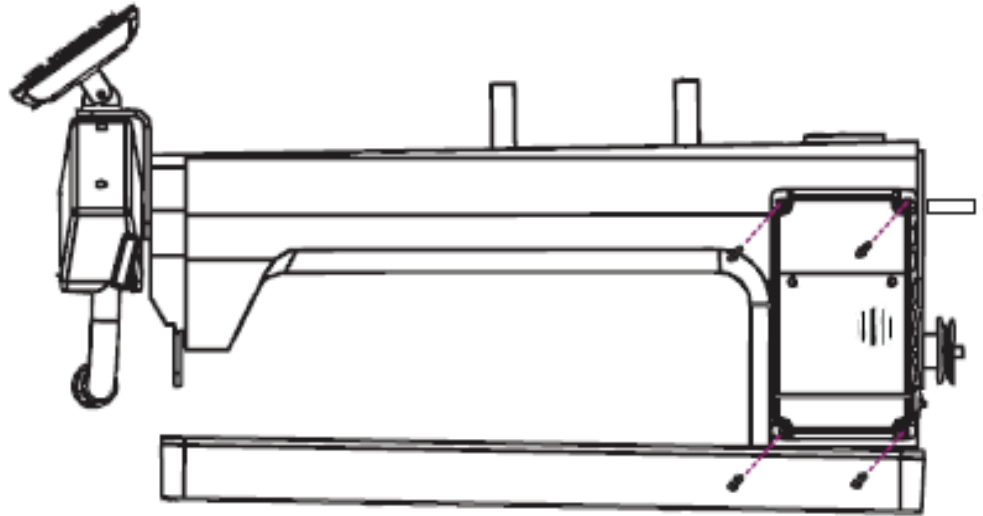

Attach the Handwheel

1. Replace the handwheel with the original screws.
2. Position the handwheel where one of the screws is directly over the flat portion of the shaft.

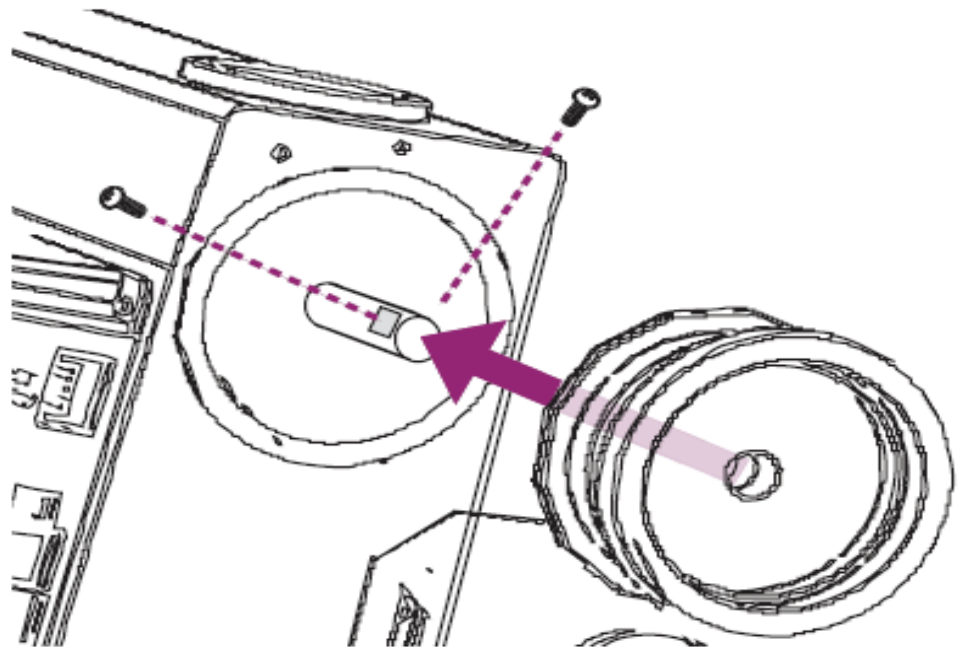

Attach the Motor Belt

1. Loop the belt around the handwheel and the motor pulley.
2. Adjust the belt tension by raising and lowering the motor on the adjustment bolts
3. Once there is only 1/4" of slack in the belt tighten the adjustment bolts to secure the motor.

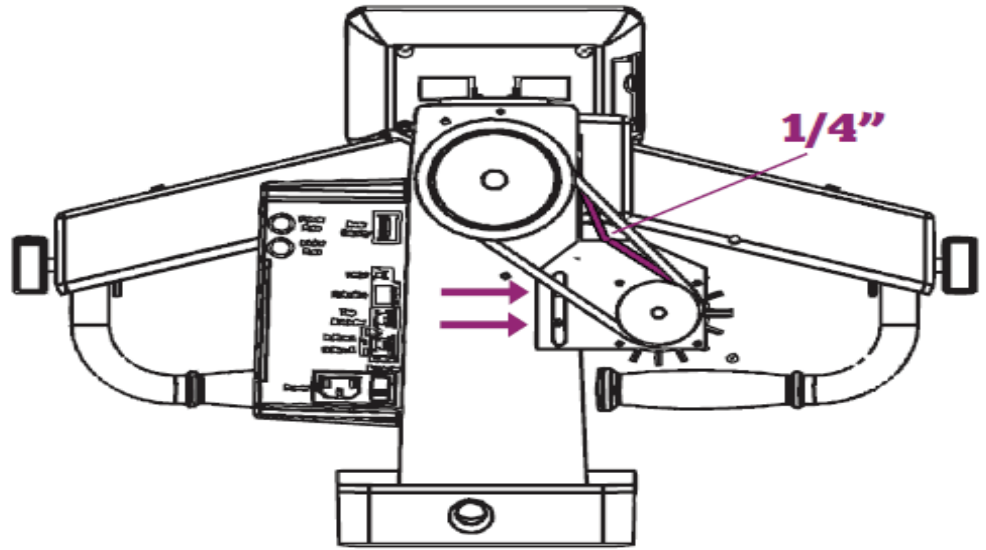

Attach the Rear Display

1. Attach the rear display to the back of the machine with two 8-32 x 1/2" screws.

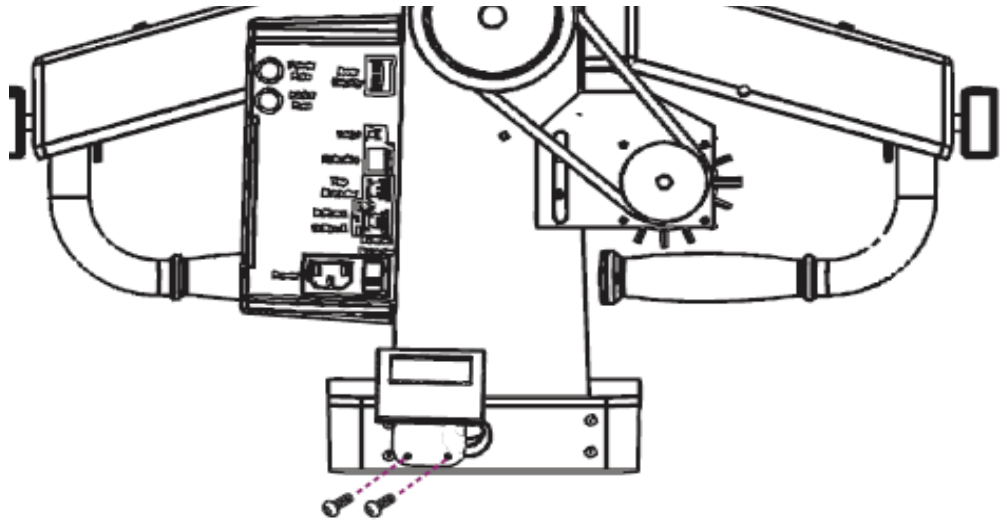

Attach the Rear Handlebars

1. Insert the rear handle bar between the clamps.
2. Insert two 1/4-20 x 1 1/2" screws through the clamps
3. Repeat for the other bar.

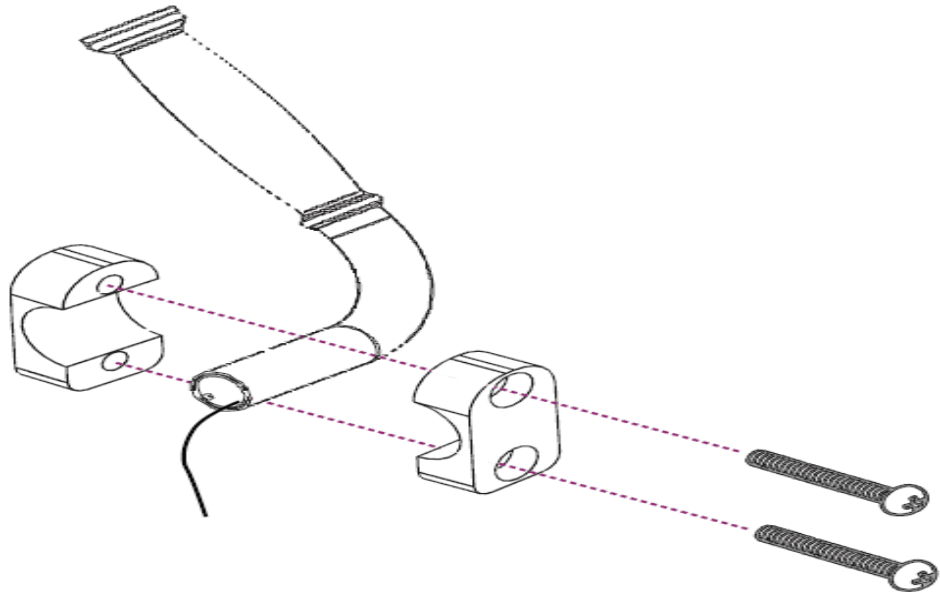

4. Attach the handlebars to the machine. Alternate tightening bolts a little at a time to make sure the clamp goes on correctly.

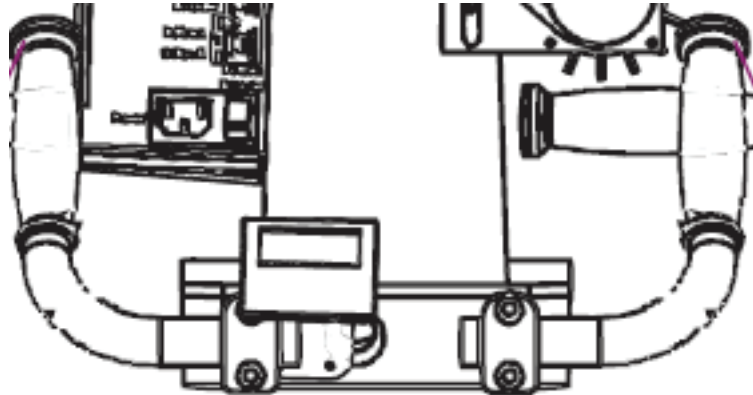

5. Attach the buttons with the blue and white on the left, and the red and green on the right.

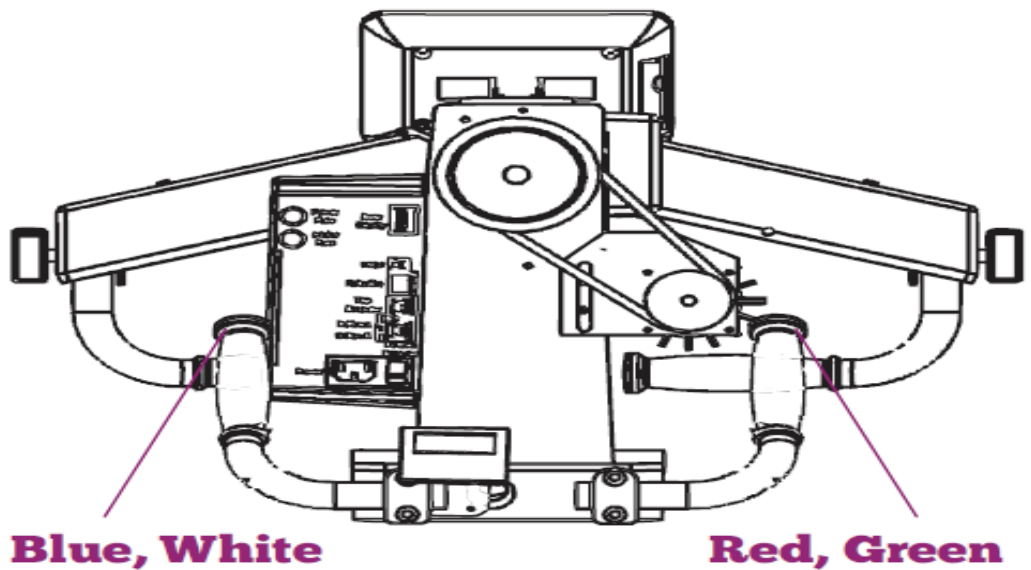

Plug in th Rear Handlebars

1. Slide the handlebar cap onto each handlebar wire.
2. Plug the handle bar wires into the ports on the bottom of the display. Use respective sides.
3. Tuck the remaining wire inside the handlebar and attach the cap over the handlebar.
4. Attach the rear display wire to the control box port labeled rear display.

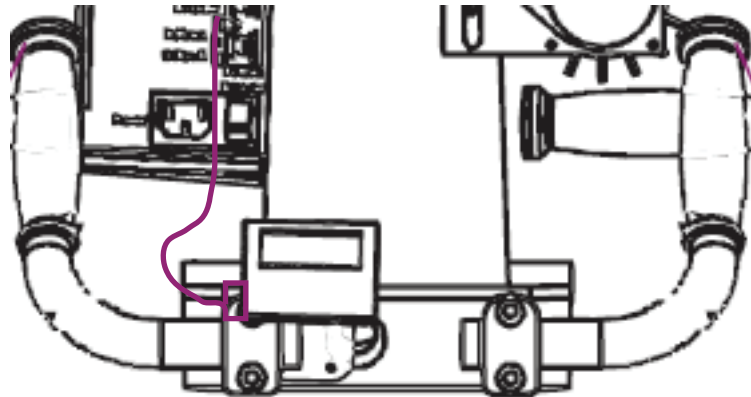
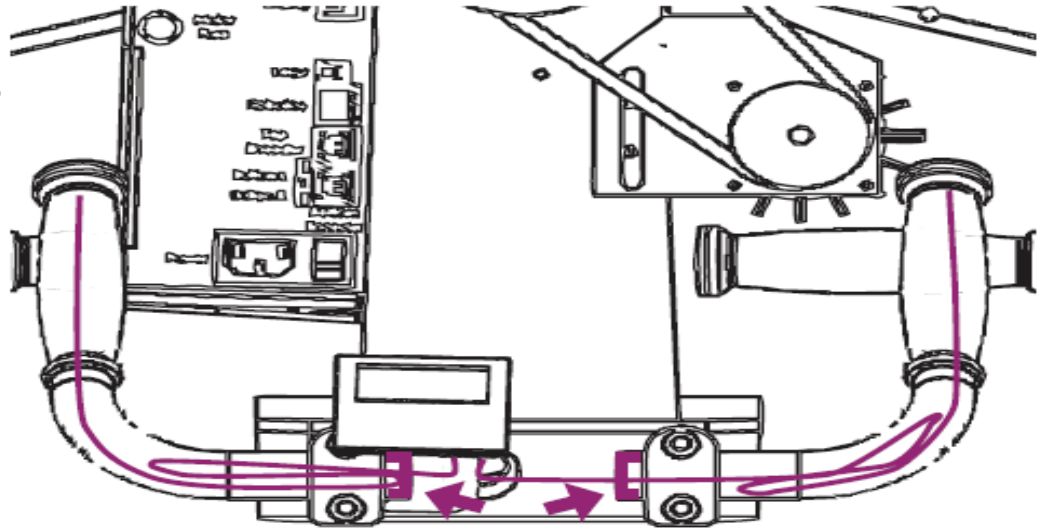

Attach the Rear Access cover

1. Reinstall the rear access cover with its original screws.

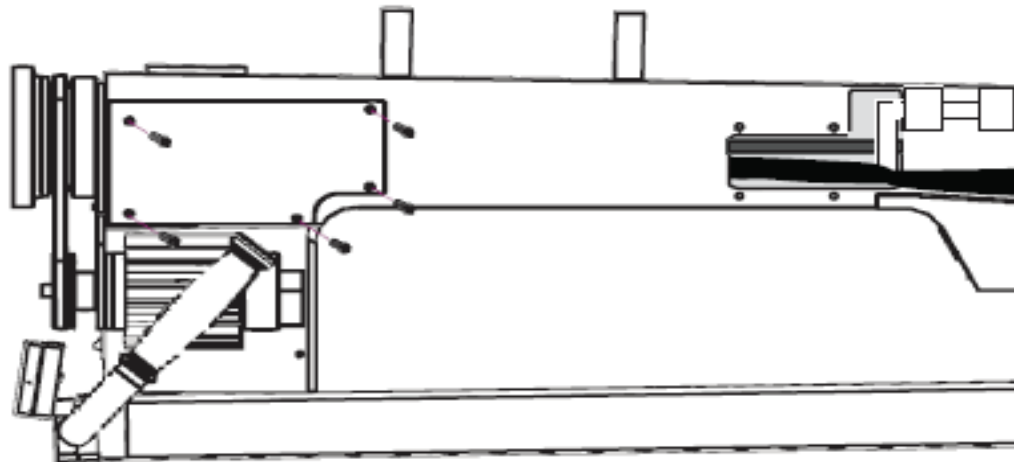

Attach the Rocker Arm Cover

1. Slide the handlebar and display wires into the lower recess of the Perfect Stitch rocker arm cover.

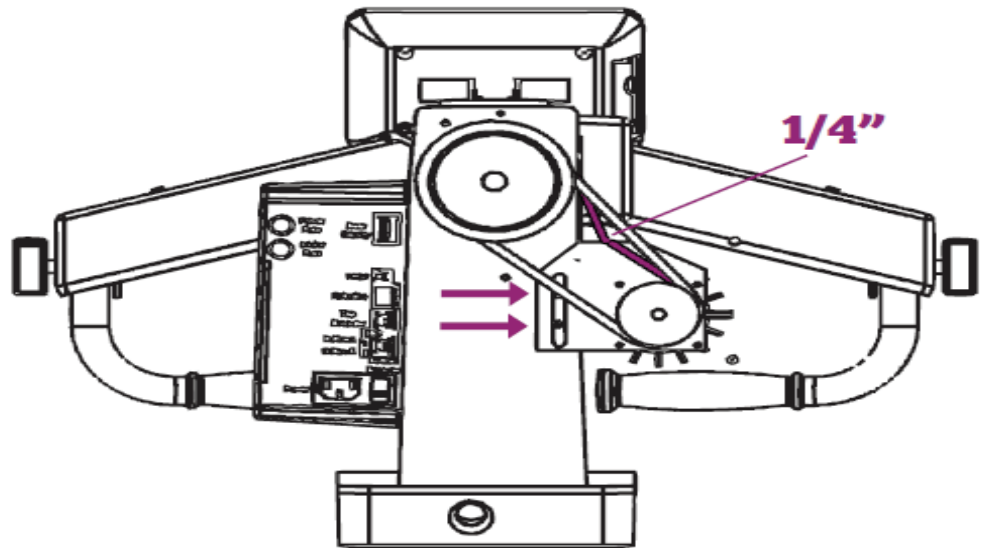

2. Attach the rocker arm cover with three of the original cover screws.
3. To avoid rubbing on the rocker arm place the cover as high as possible before tightening.

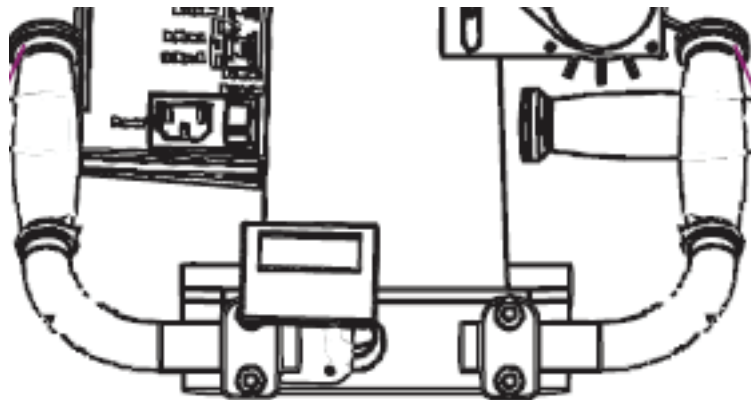

Note: Because casting can vary from machine to machine alterations may need to be made to the rocker arm cover.

If the Faceplate has no Hole

1. Mark where the screw should go with a pencil.
2. Remove the rocker arm cover, handlebars, and faceplate.
3. Use a hammer and punch to mark the point, drill with a #29 bit, and tap with an 8/32 tap.
4. Reassemble the faceplate, handlebars, and rocker arm cover.

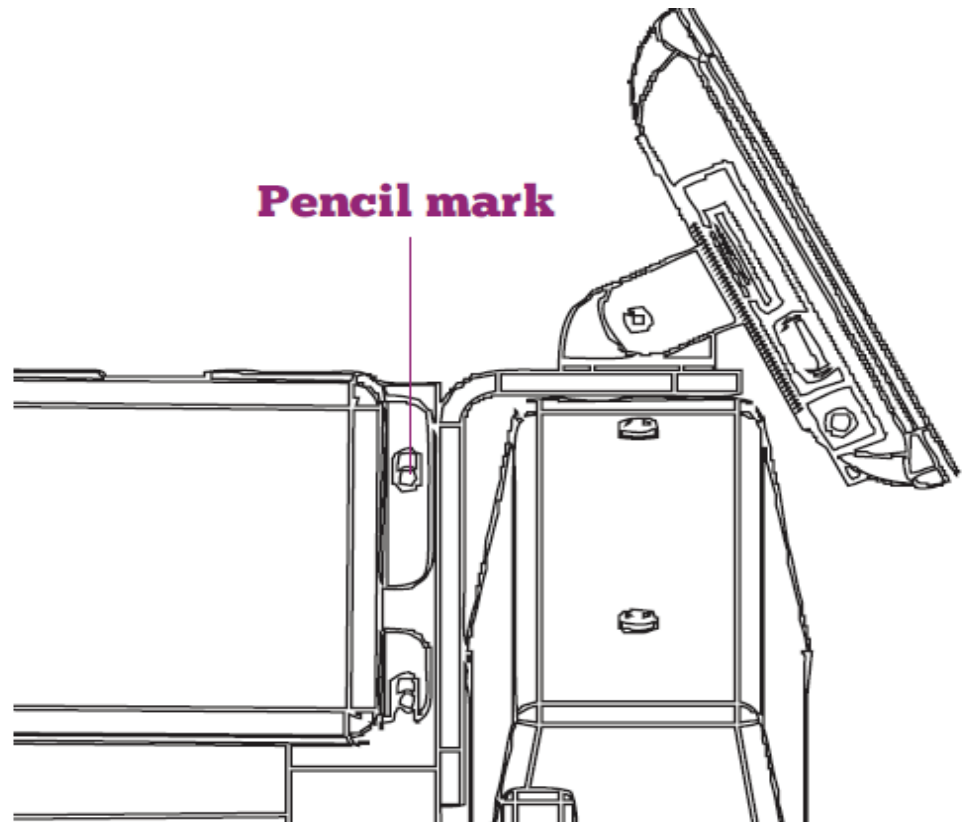



Quilt
EZ

The title 'Quilt EZ' is rendered in a warm, orange-brown color. The letter 'Q' is significantly larger than the other letters and features a black needle and thread graphic passing through its center. The word 'Quilt' is in a serif font, while 'EZ' is in a bold, blocky sans-serif font. The thread from the needle forms a decorative loop below the 'Q'.

Tin Lizzie 18 (Ribbon Cable) Drill Templates

When printing PDFs, DO NOT select fit to page, otherwise the template will be distorted when printed.

To ensure the template has printed correctly, align the Control Box with the four (4) #29 drill bit drill holes in the template prior to drilling.

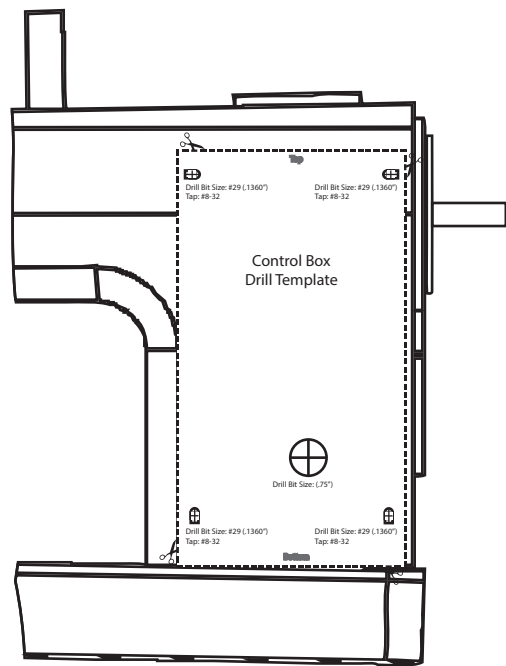
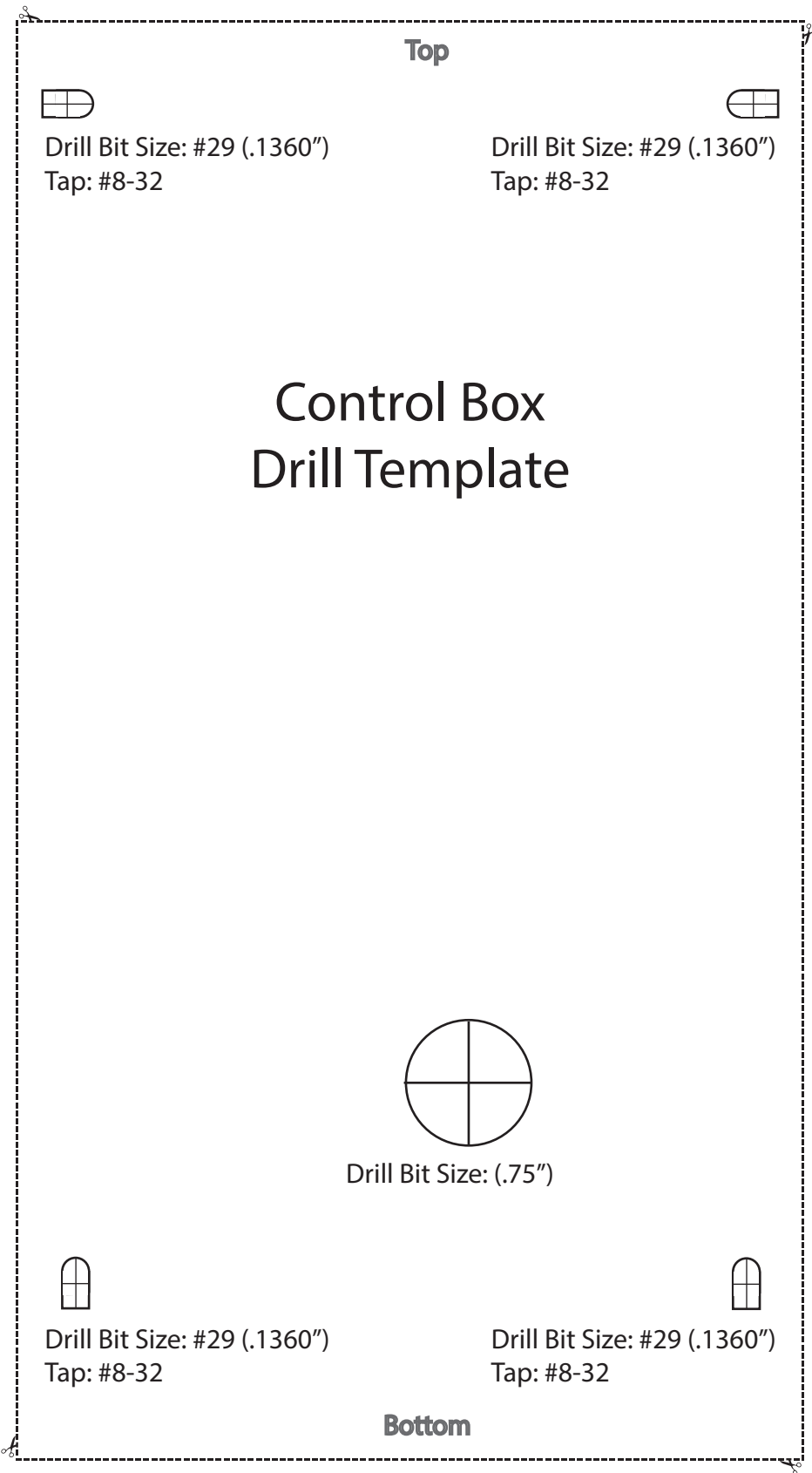

Tin Lizzie 18 (Ribbon Cable) Drill Templates

Top

○
Align
with
factory
drilled
hole

Motor Side Drill Template

○
Align
with
factory
drilled
hole

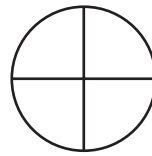

(.75") Drill bit size

Bottom

When Printing PDFs,
DO NOT select fit to
page, otherwise the
template will be
distorted when
printed.

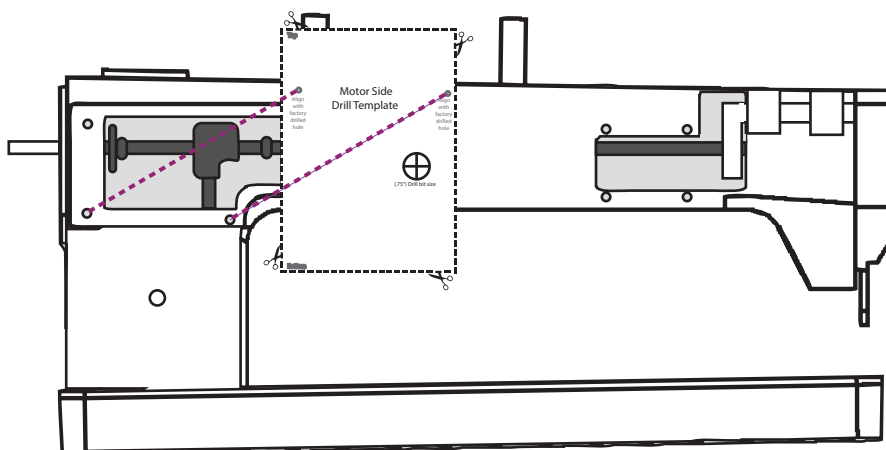

Tin Lizzie 18 (Ribbon Cable) Drill Templates

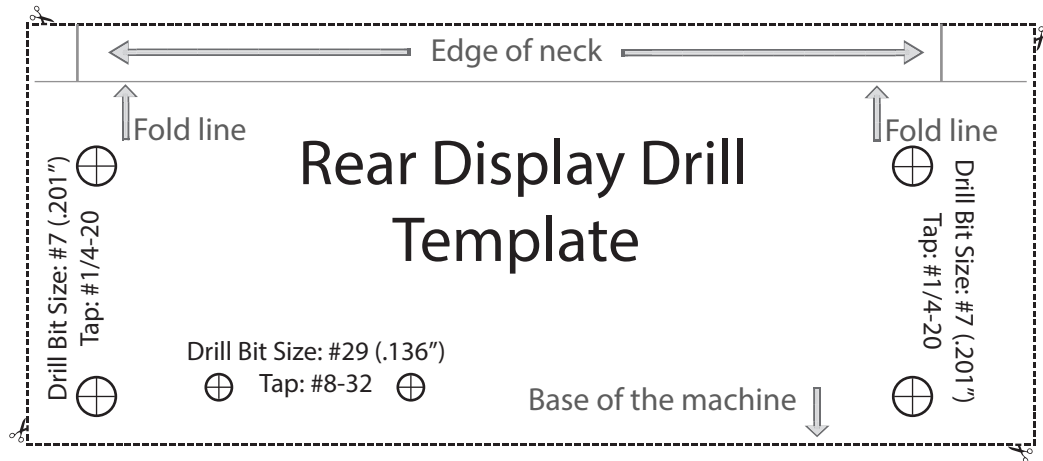

When Printing PDFs, DO NOT select fit to page, otherwise the template will be distorted when printed.

To ensure the Template has printed correctly, align the rear display bracket with the two (2) #29 drill bit drill holes in the above template prior to drilling.

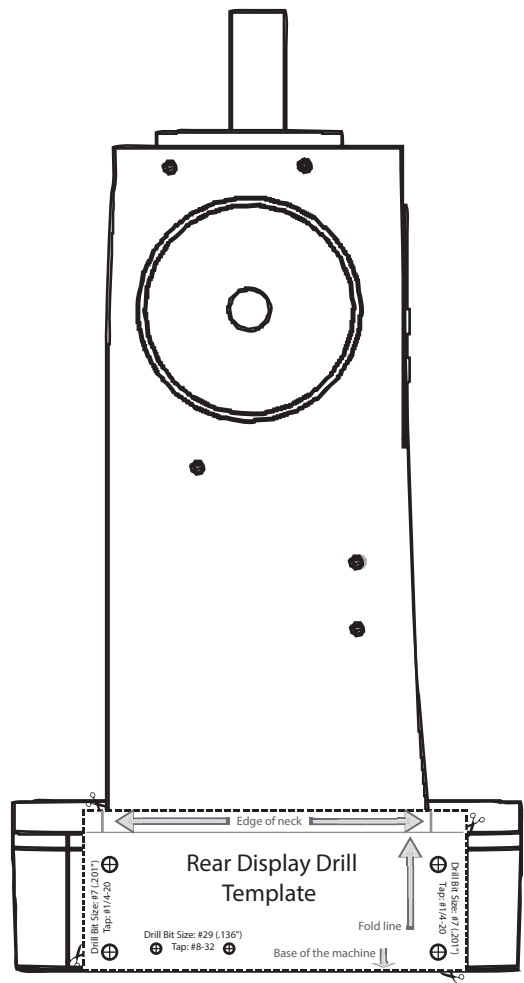

Tin Lizzie 18 (Ribbon Cable) Drill Templates

Remember the Index Sensor drill point is only necessary if there is no suitable factory drilled hole.

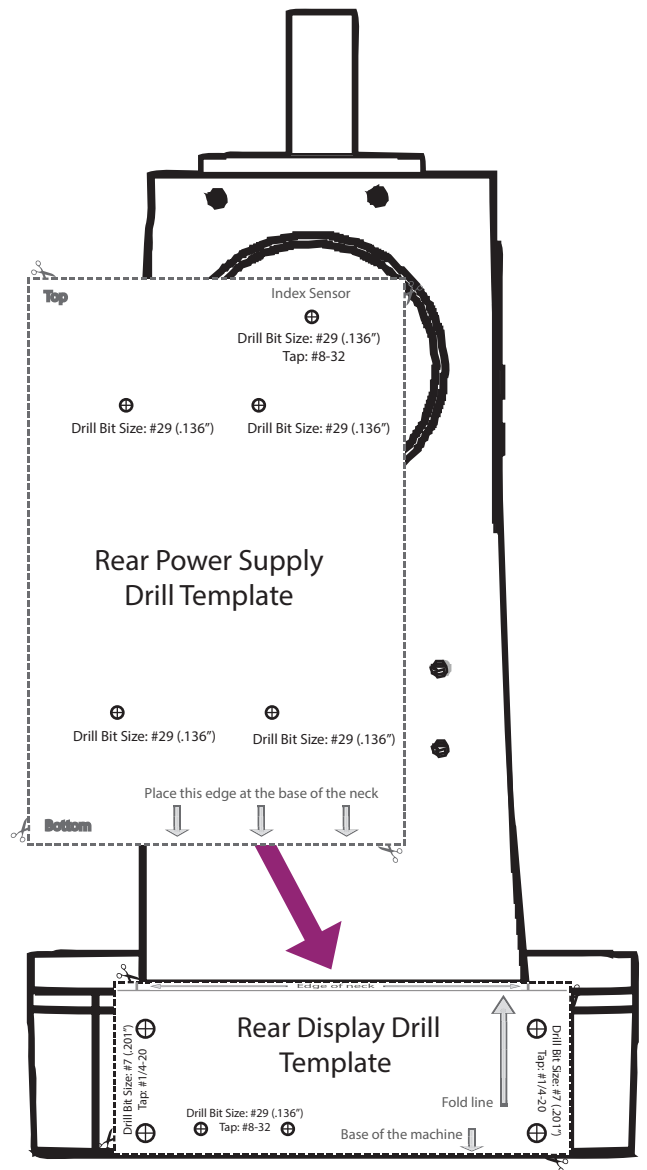
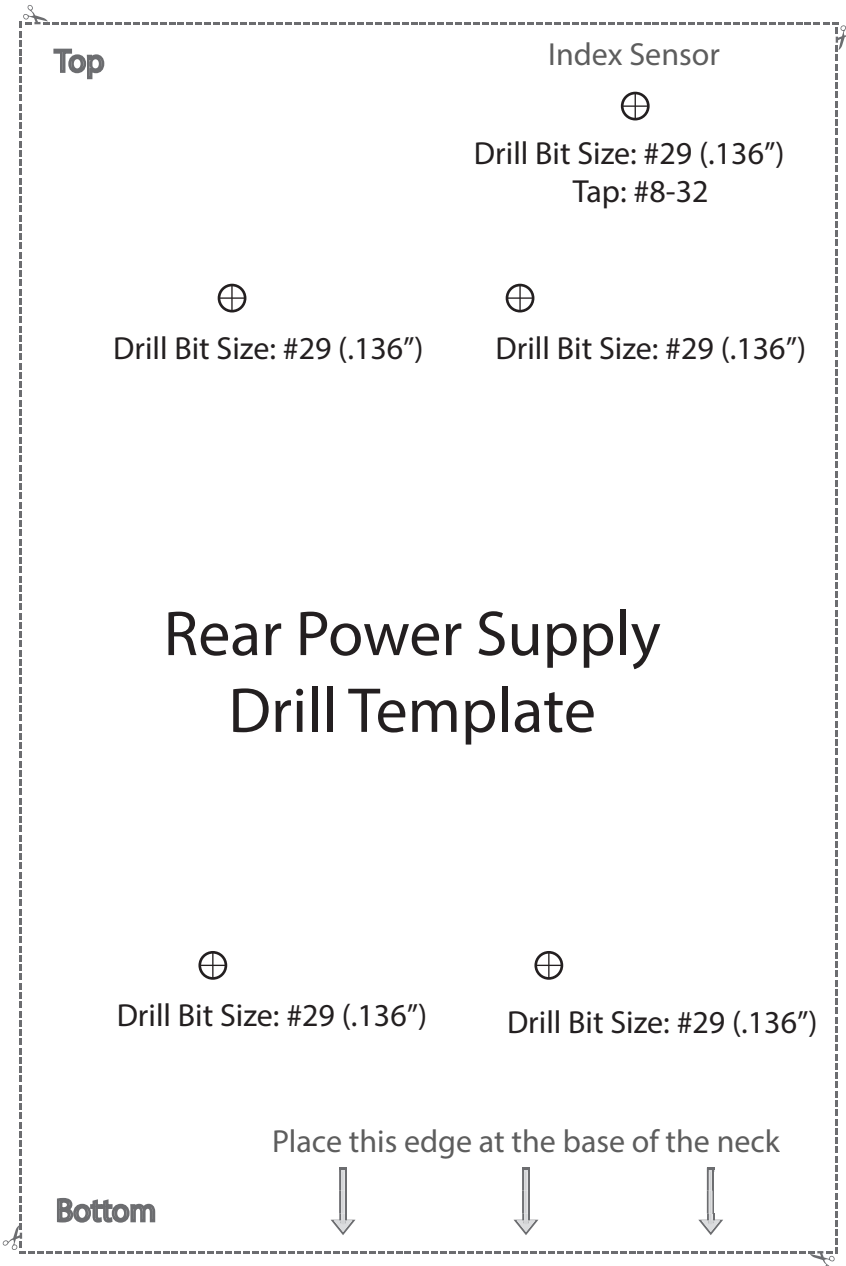

When Printing PDFs, DO NOT select fit to page, otherwise the template will be distorted when printed.

To ensure the Template has printed correctly, align Standoffs of the rear power supply with the four (4) #29 drill bit drill holes in the above template prior to drilling.

PerfectStitch Handlebar Drill template

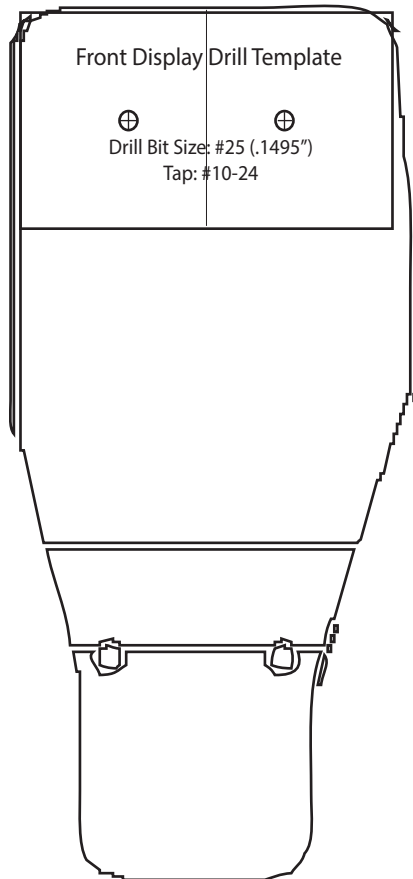
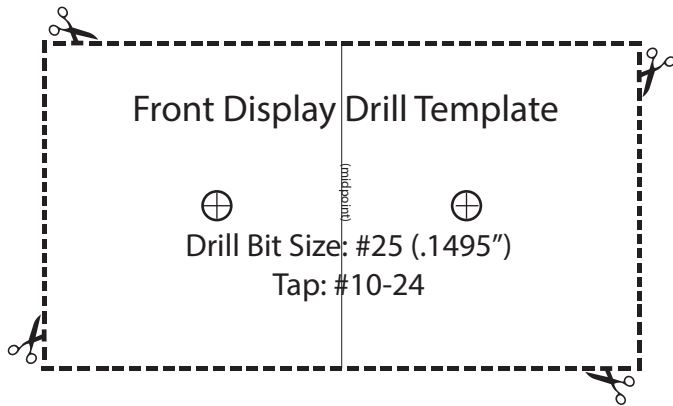

When printing PDFs, DO NOT select fit to page, otherwise the template will be distorted when printed.

To ensure the template has printed correctly, align the Handle Bar Bracket with the two (2) #25 drill bit drill holes in the above template prior to drilling.

Align the drill template horizontally with the top of the machine, with the midpoint as close to center as possible.

How high the the template sits is up to customer preference. Base it on desired height for the handlebars.