

Quilt
EZ

Perfect Stitch

Machine Upgrade

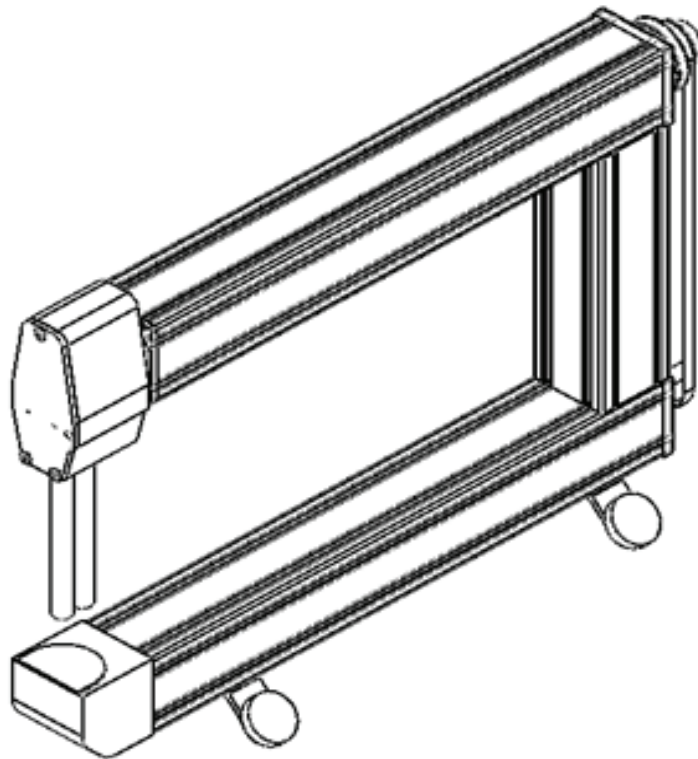

Prodigy Machine Upgrade

Machine Checklist

BE SURE TO TEST THE MACHINE BEFORE REMOVING ANY ELECTRONICS.

1. All cables run properly and will not be caught by any moving parts
2. All cable plugged into their respective locations and seated well
 - a. Will not come unplugged if vibrated.
 - b. Might want to have them address each cable here...showing pictures of well seated and not well seated cables.
3. All screws tight for all pieces
 - a. Will not come loose after vibration.
4. Belts a good tension
 - a. Discuss belt tension and how it should not be extremely tight, but also should not easily slide, needs some give, but also some tension.
5. After all pieces confirmed power on system.
6. Confirm the display comes up and communicates
 - a. If gives the communication error should refer them to their trouble shooting guide, to a specific step.
7. Have them go into the system – additional settings and set the motor ratio.
 - a. Don't forget to BOLD to check the box to “load ratio” when the machine starts. Explain if they don't check this box the ratio will default and need up position will not be proper.
8. Confirm all system settings:
 - a. Index working
 - b. Motor encoder working
 - c. Carriage encoders working – add the encoder test sheet to this section
 - d. Lights working
 - i. White Lights on and dimming
 - ii. Black lights turning on (if available)
 - iii. Laser working (if available)
9. Run manual stitch for 5 minutes, confirm all good
10. Run regulated for 5 minutes faster and slower, confirm all good.
11. Run Idle for 1 minute, confirm
12. Run baste for 1 minute: confirm the needle stops up each time.
 - a. IF it does not stop consistently in the up position, go into the motor settings
 - b. Additional setting – PID Settings
 - c. Change the “stat position – KD” to .0012
13. IF the unit has rear handle bars:
 - a. Confirm all 4 buttons function
 - b. Confirm rear display communicates and functions

Pulley Size

To get the correct measurement of pulley needed for your machine you will need to measure how long your current machine pulley is.

Measure the machine pulley from end to end.

Once measure you will Divide by 1.5

This will be giving you the ratio and corresponding size of pulley, keep in mind that you get an exact number. You will need to round to whatever number it is the closest to.

Pulley Sizes

1"

1 1/2"

2"

3"

You will then decide which one of the listed pulley sizes you will need for your machine.

Tools Required

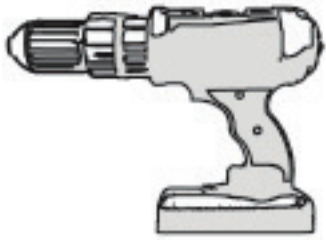

Hand Drill



#29 (.1360") Drill Bit
#25 (.1495") Drill Bit
#7 (.2010") Drill Bit
3/4" (.75") Drill Bit



Safety Glasses



Flat Head Screwdriver



Phillips Screwdriver
(#1 and #2)



Wrench or Socket Set
(Standard and Metric)



Hex Key Set
(Standard and Metric)

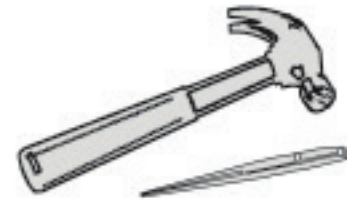

Hammer and Punch



Tap Wrench



#1 4/20 Tap
#8-32 Tap
#10-24 Tap



Tapping Oil

Perfect Stitch Parts

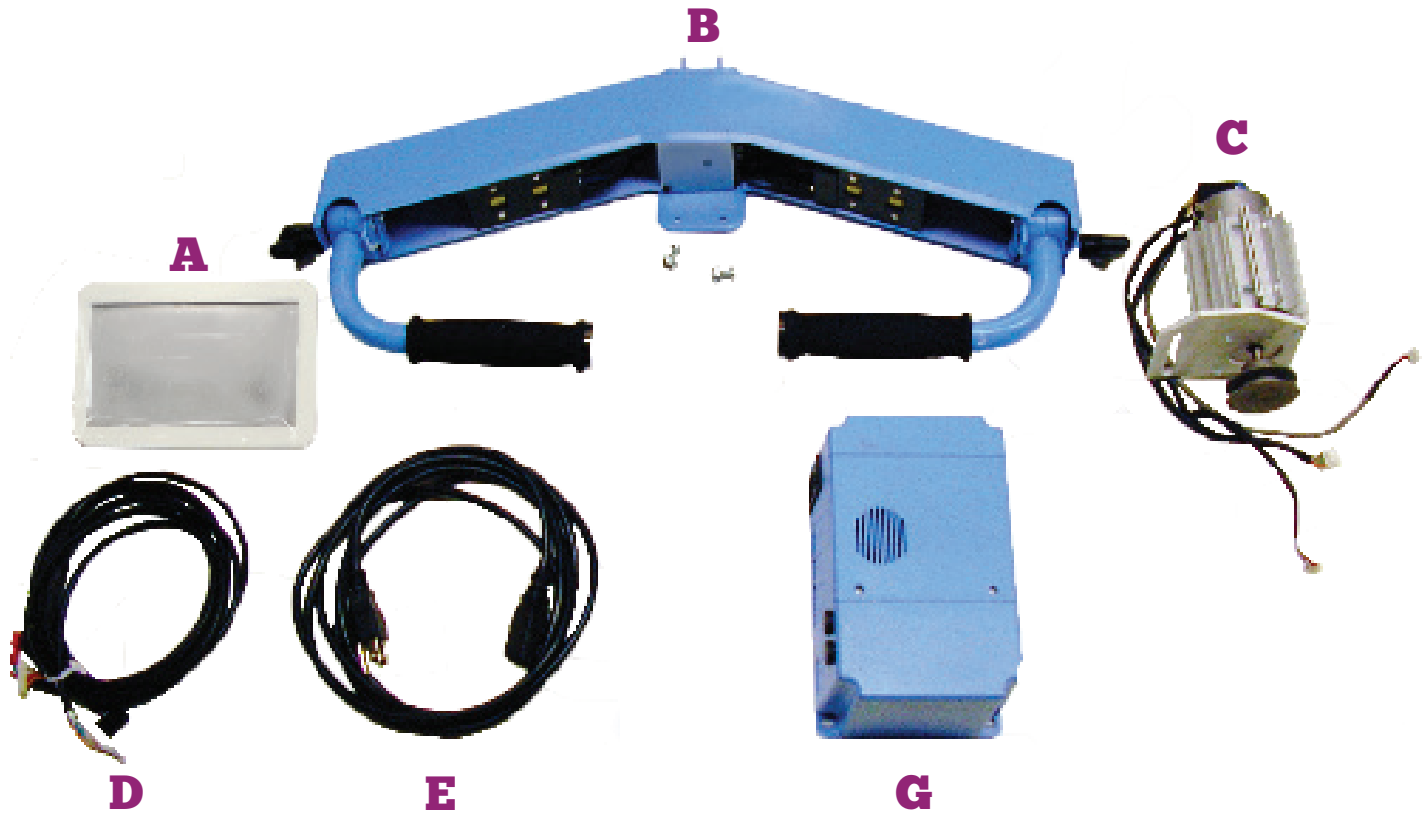

Letter	Description
A	Display
B	Handle Bars
C	Motor
D	Handle Bar Wires
E	Power Cord
F	Control Box
G	PCB Box
	(part colors may differ from current picture)

Removing Electronics from machine

Be sure to test machine and ensure that all components are working before removing any electronic pieces.

1 Remove all current electronic components from the machine.
This includes Motor, Electronic box, wiring, and any belts.

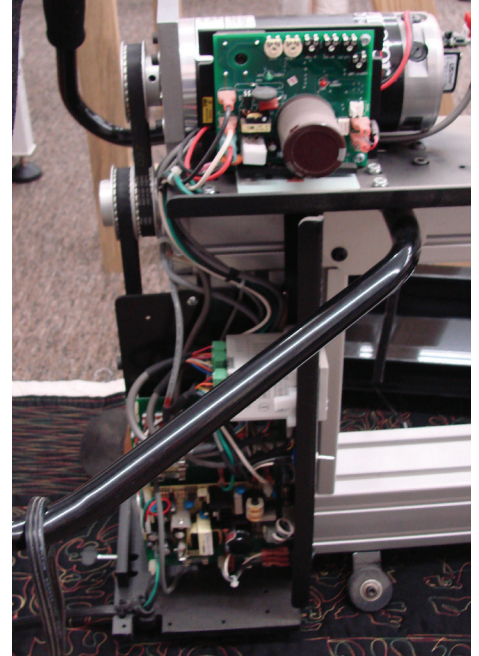
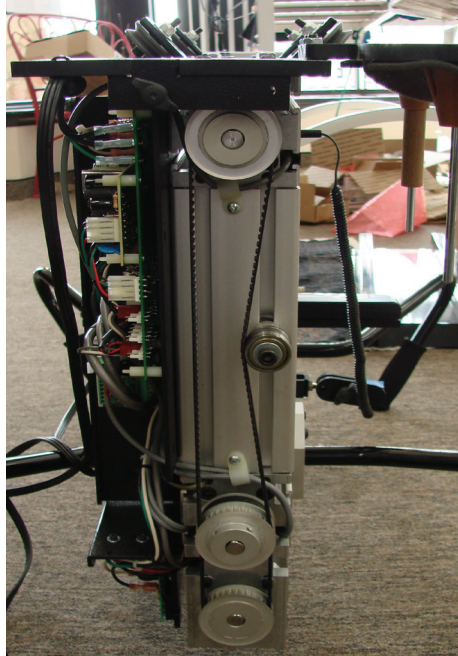

2 Remove the plastic clear plate from the front end of the machine.

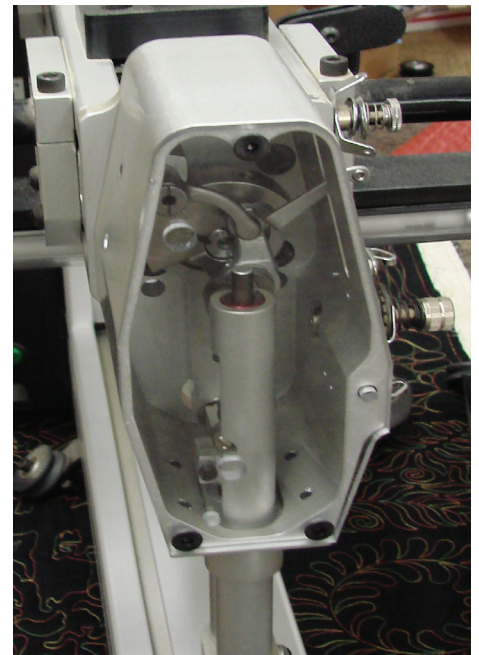
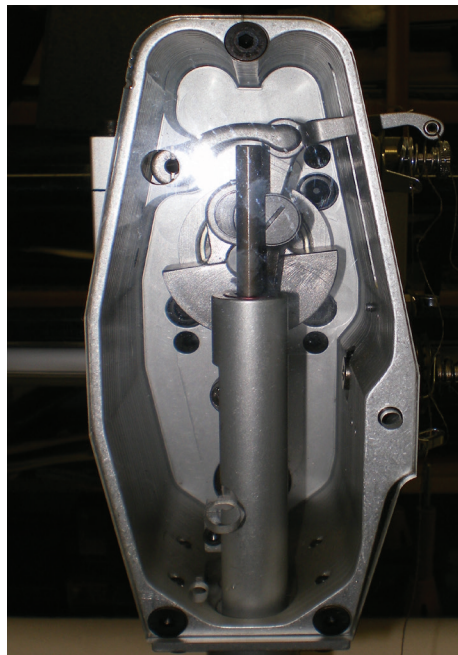

Attaching Front Plate

- 1 Locate the front of the machine.

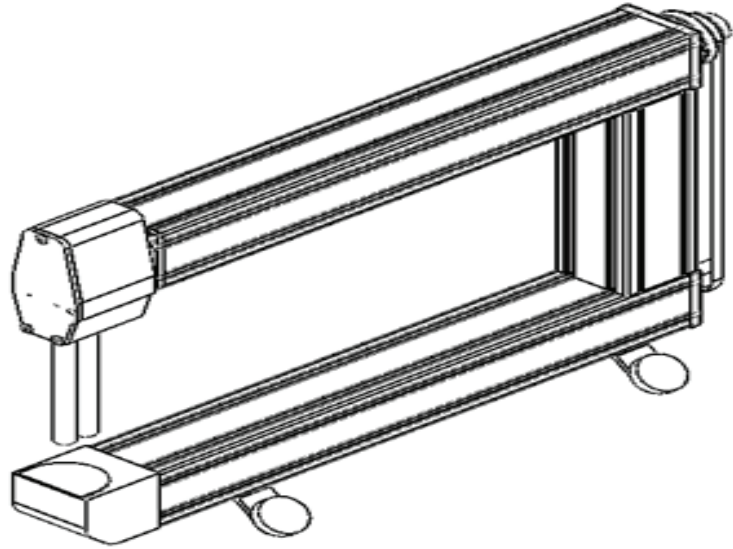

- 2 Attach the front metal plate using the **(3) 1/4-20 x 1/2" screws** that are provided in the bag listed below.

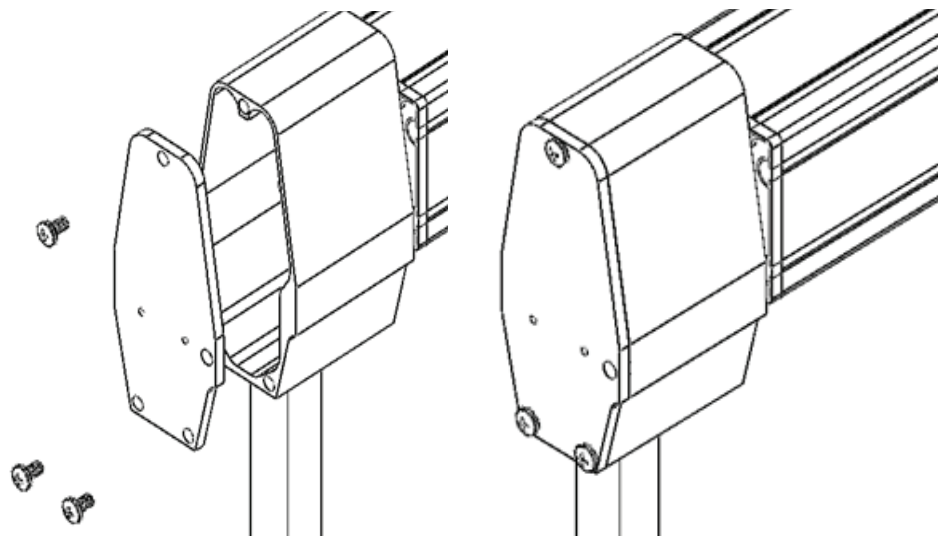

Attaching Handle bar

1 Align the handlebar to the Front metal plate that was previously installed.

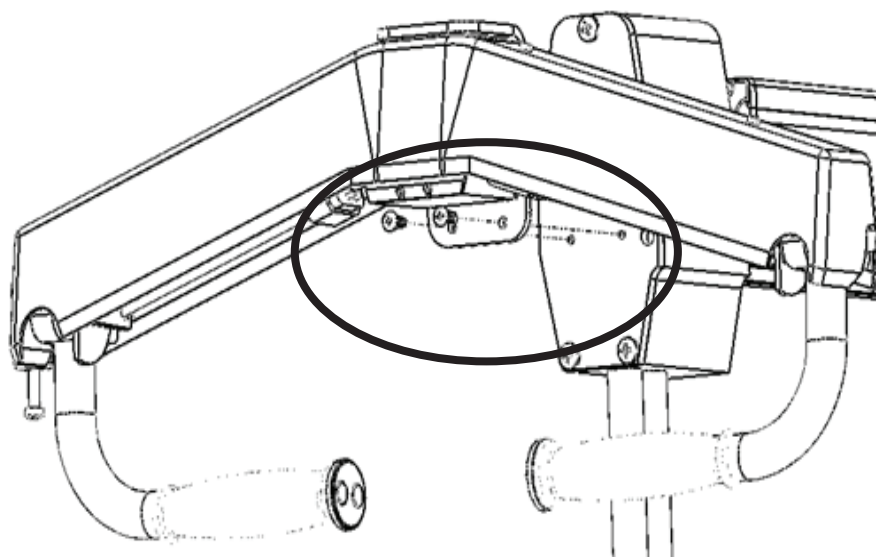

2 Mount the Handlebar to the front metal plate using the **(2) 10-24 x 1/2" screws**.

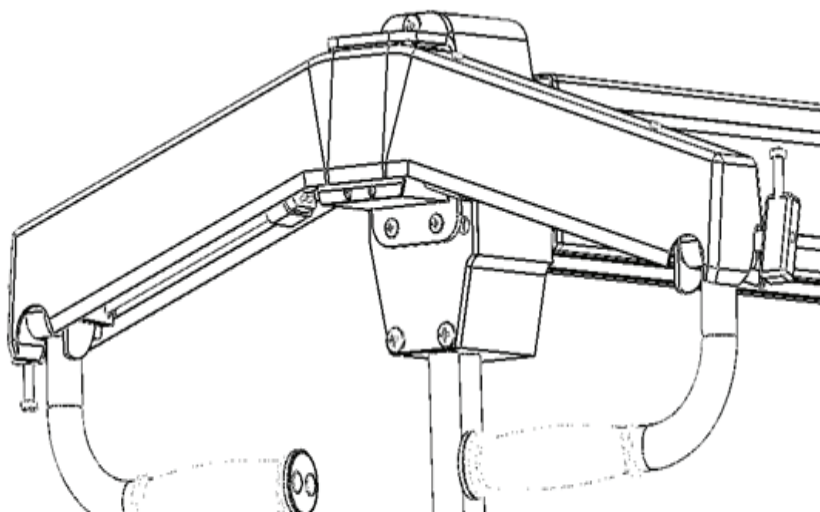

Attaching 7" Display

1 To attach the Remote bases to the Handlebar you will need to remove **(2) screws** from the current bracket that is mounted on the top of the Handle bar.

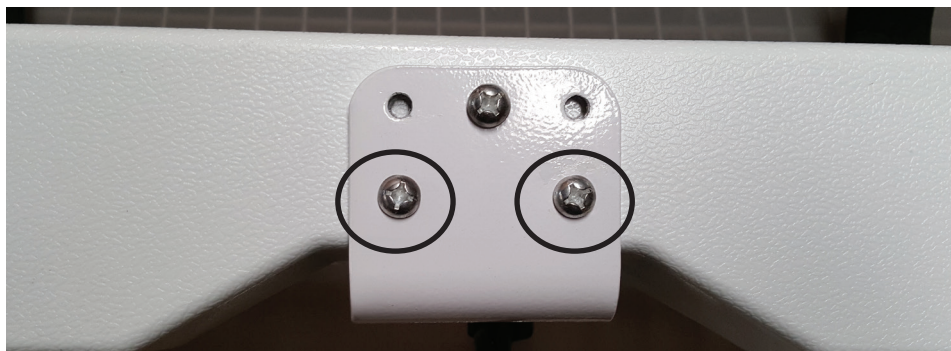

2 After removing the (2) screws from the bracket, align the remote bases to the bracket.

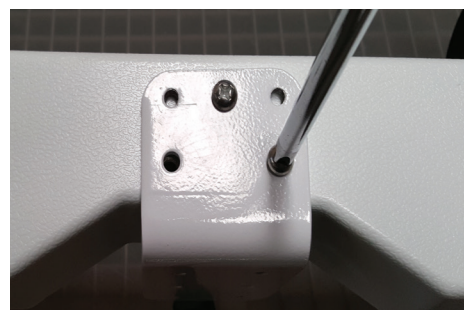
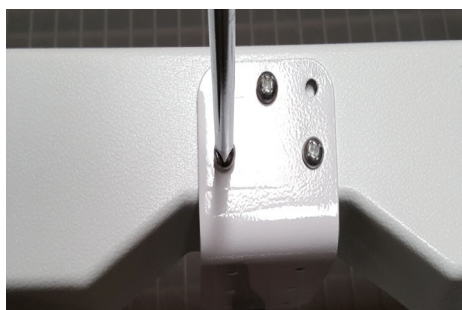

3 Reinstall the same screws that were just removed.



4 You will need to use **(2) M6 x 8 screws** to hold down the remote bases from sliding.

You will find these in the bag listed in step 1.



Pictures and color may be different from your machine.

Attaching 7" Display

5 You will be attaching the display to the remote bases using **(2) 8-32 x 1/2" screws** and plastic washers that are provided.

Make sure to not tighten down the screws to much other wise this will cause your display to not be able to move.

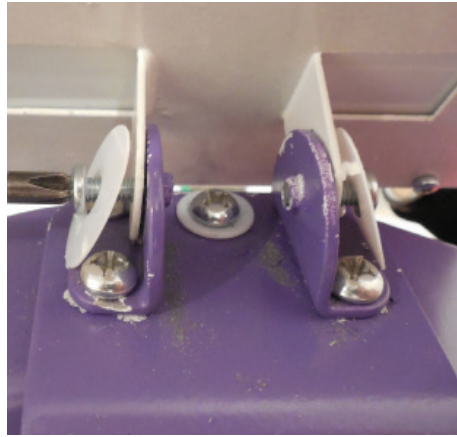
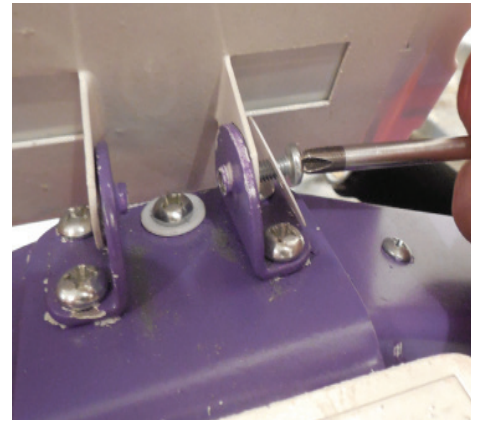

Pictures and color may be different from your machine.

Attaching Magnetic Index

- 1** You will attach the **3" pulley** with the Magnetic Index collar to the top shaft of the machine.

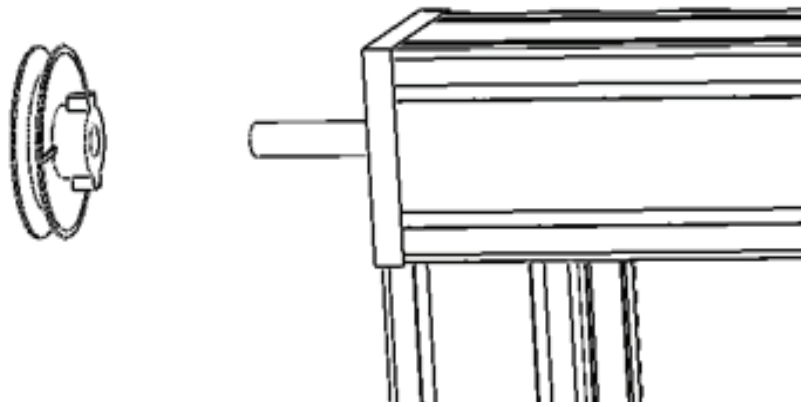

- 2** Before tightening down the pulley to the shaft of the machine, you will need to make sure to turn the hand wheel and ensure that it is in the needle up position. Once in the needle up position you can go ahead and tighten down the pulley.

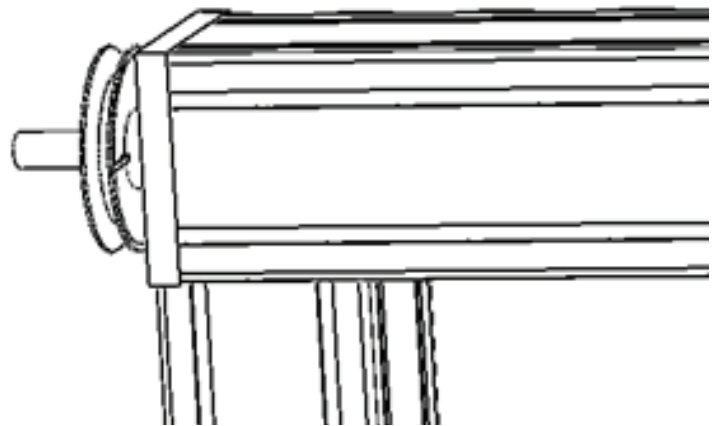

- 3** Using the Magnetic Index Bracket you will align it to the machine so that the Index Sensor aligns with the magnet on the pulley.

Once aligned in its corresponding location, using a pencil or marker you will mark where you need to drill.

You will be using a **#29 Drill bit**.

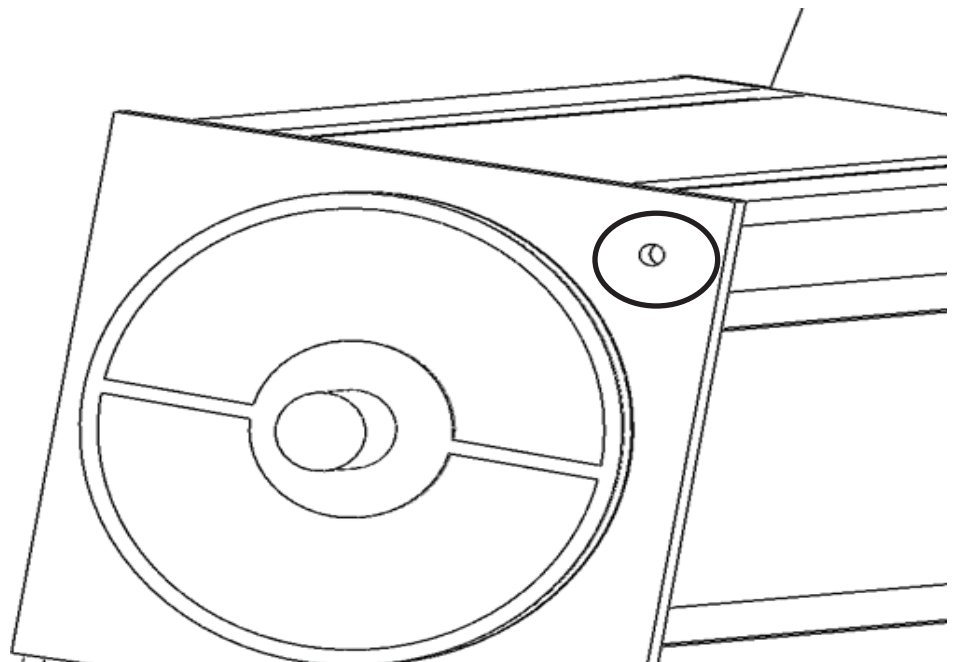

Attaching Magnetic Index

4 After the hole has been drilled you will be using a **8-32 tap**. You will need to tap the hole you just drilled in order for you to be able to attach the Index Bracket to the machine.

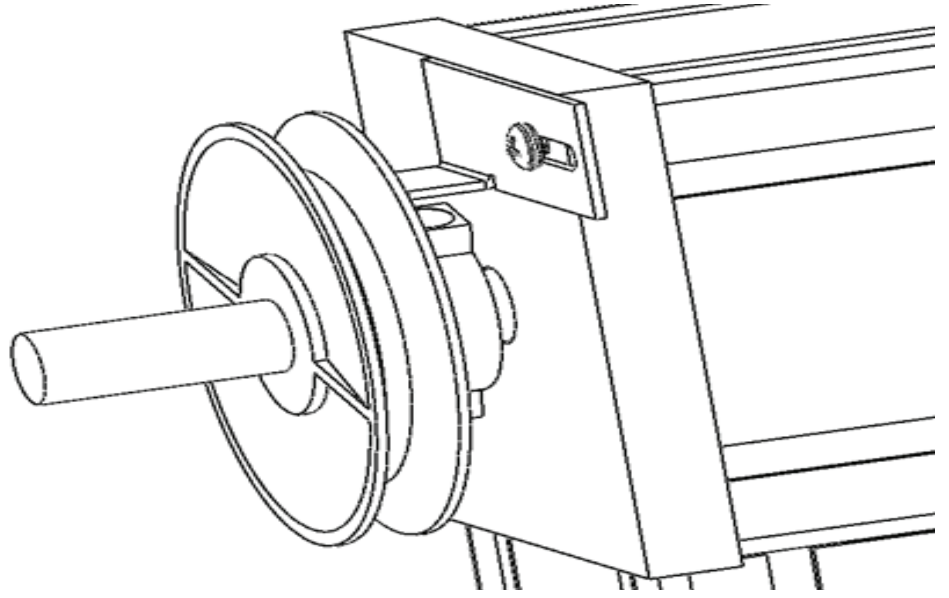

5 You will then mount the Index Bracket to the machine using the **8-32 x 1/2" Screw**.

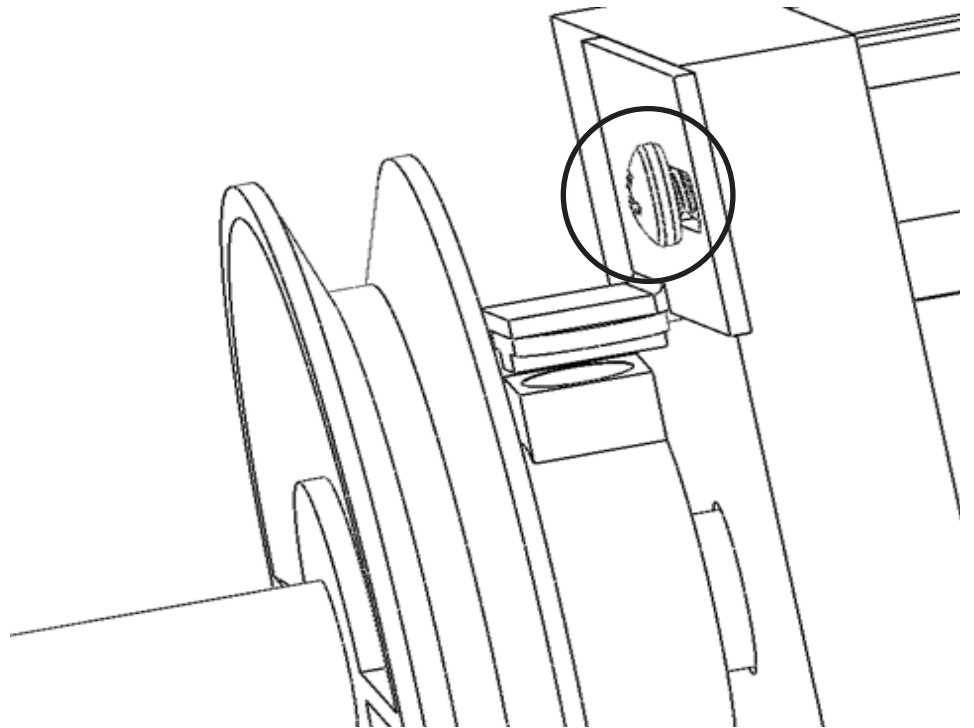

Attaching Motor

1 You will be attaching the Motor Bracket to rear end of the machine.

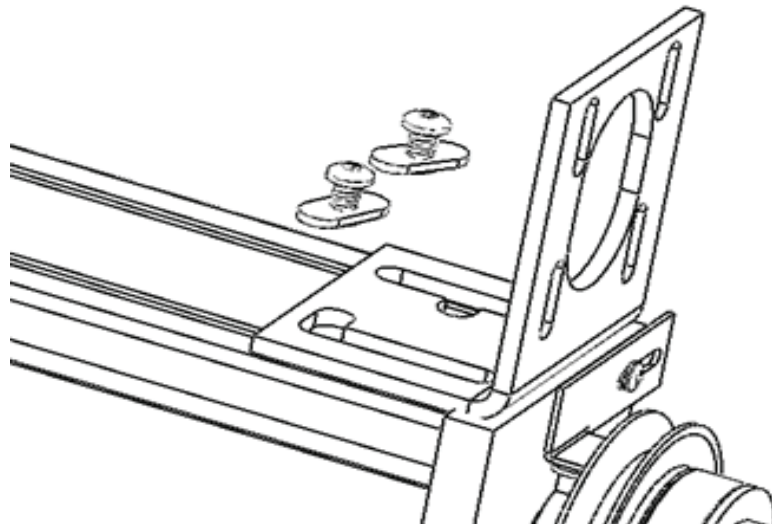

2 Using **(2) T Nut screws**, you will be attaching the bracket to the machine.

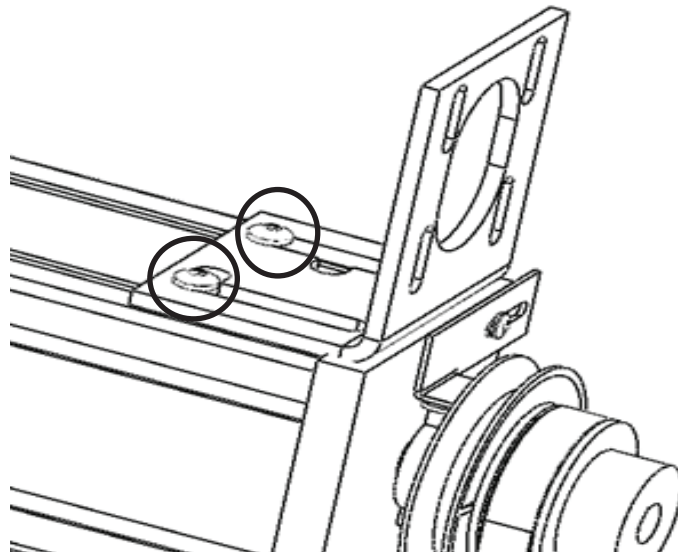

3 Once the bracket has been mounted you will go ahead and mount the motor.

You will be using **(4) 10-24 x 1/2" screws with nuts** to hold the motor in place.

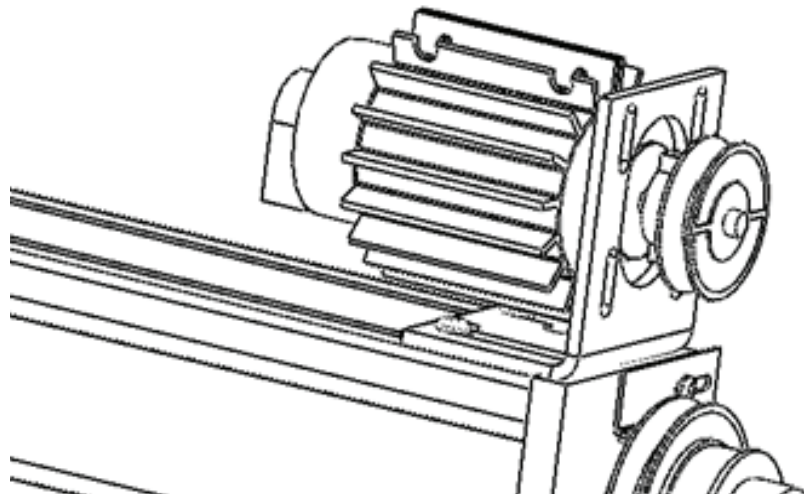

Attaching PCB Box and PCB Plate

- 1** To mount to the PCB plate to the side of your machine you will be using **(2) T Nut screws**, these will hold the plate in place.

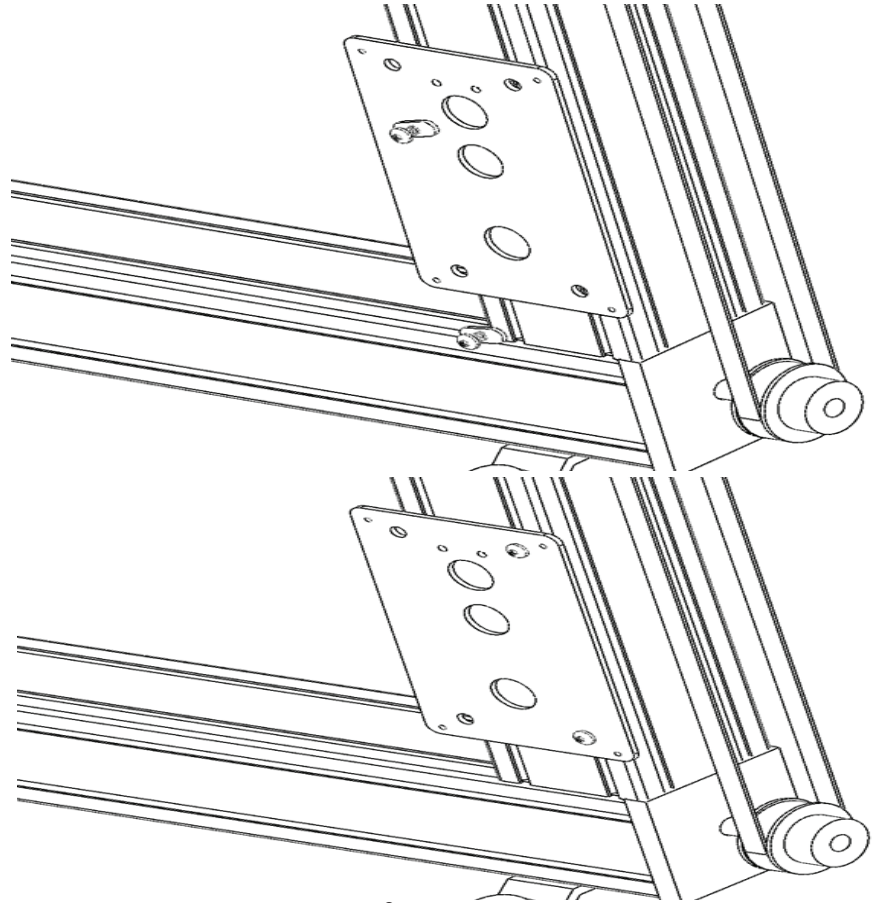

Motor Wires

- 2** **Connect Motor Wires**
Connect the motor wires as shown at right.

Each of the ports will be labeled. Be sure to plug into the correctly labeled ports on the PCB.

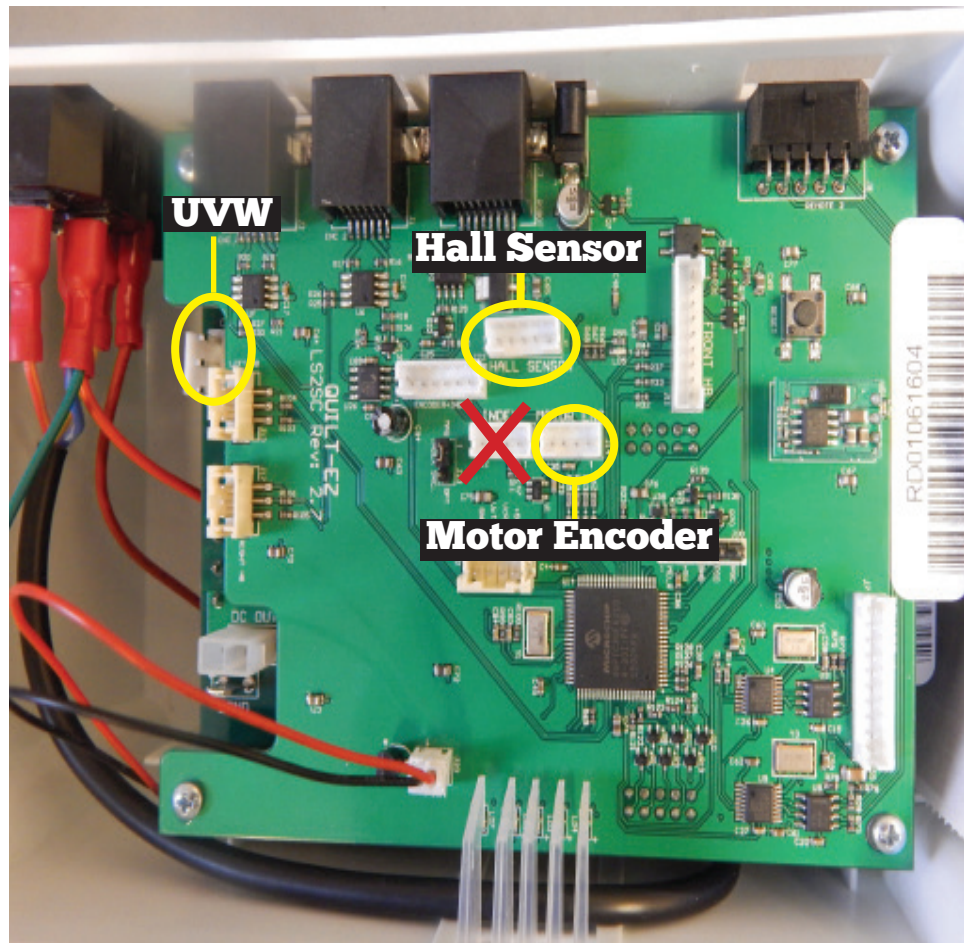

3 Connect Index, Handle Bars

Connect the handle bar and display wires as shown at right. Each of the ports will be labeled. Be sure to plug into the correctly labeled ports on the PCB.

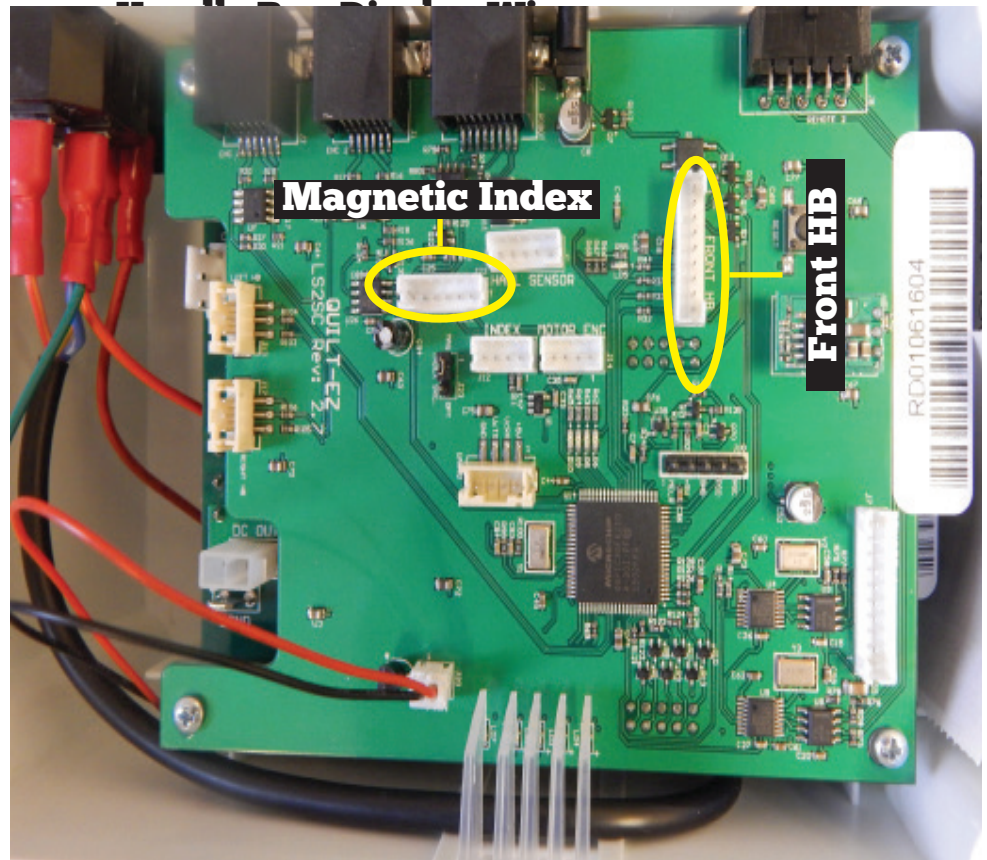

4 When attaching the PCB Box you will use (4) 8-32 x 1/2" screws.

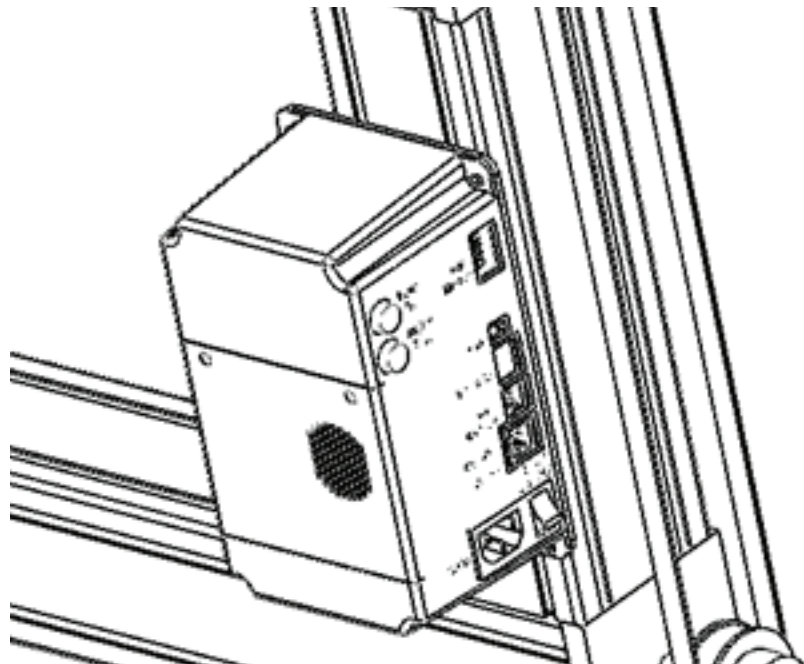

Attaching Rear Handle bars

- 1** To attach the rear Handle bars you will be using **(4) T Nut screws**. You will use two for each side.

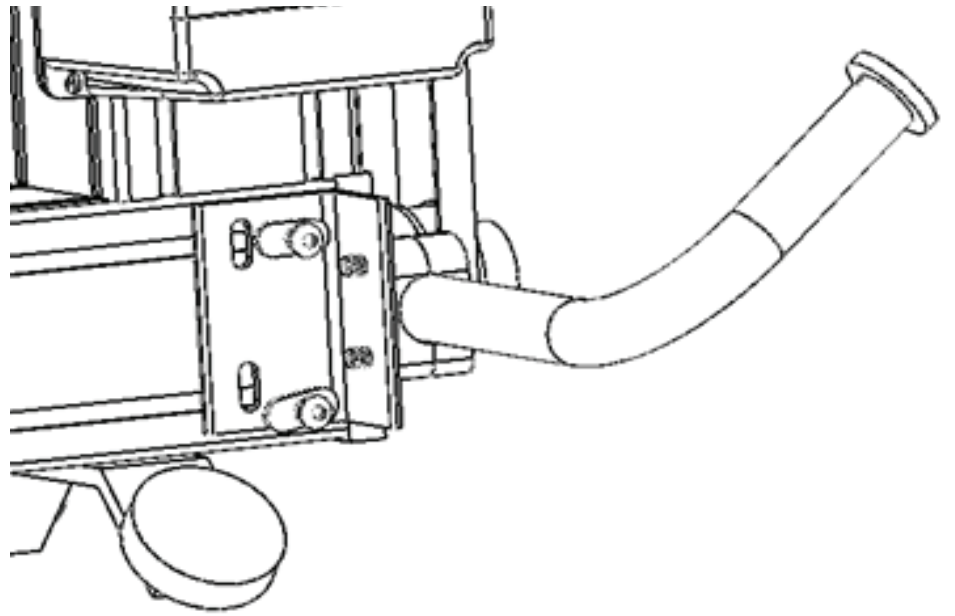

- 2** Once T Nut screws are in place, begin to tighten down.

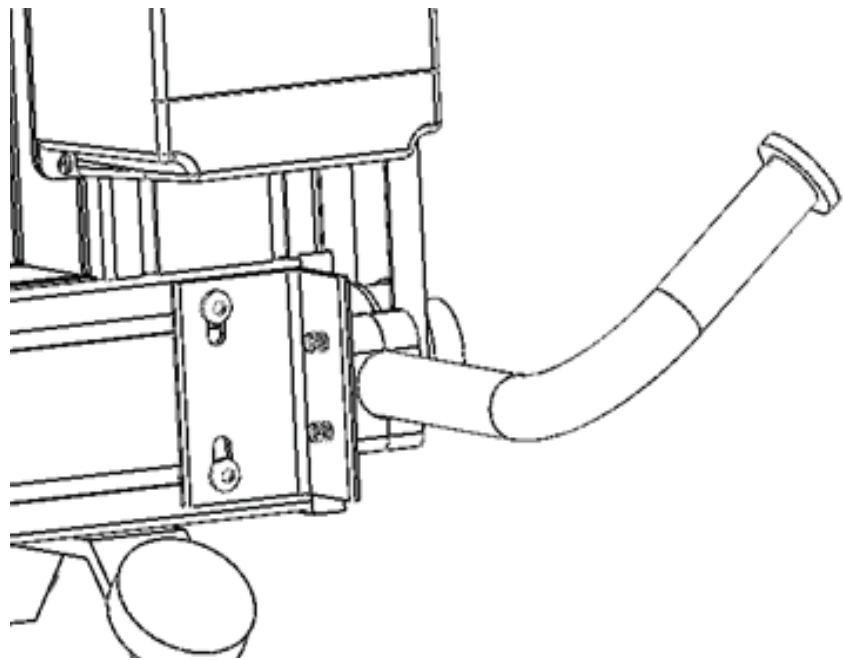

Encoder Installation

1 You will be mounting the Encoder right in front of the wheel.

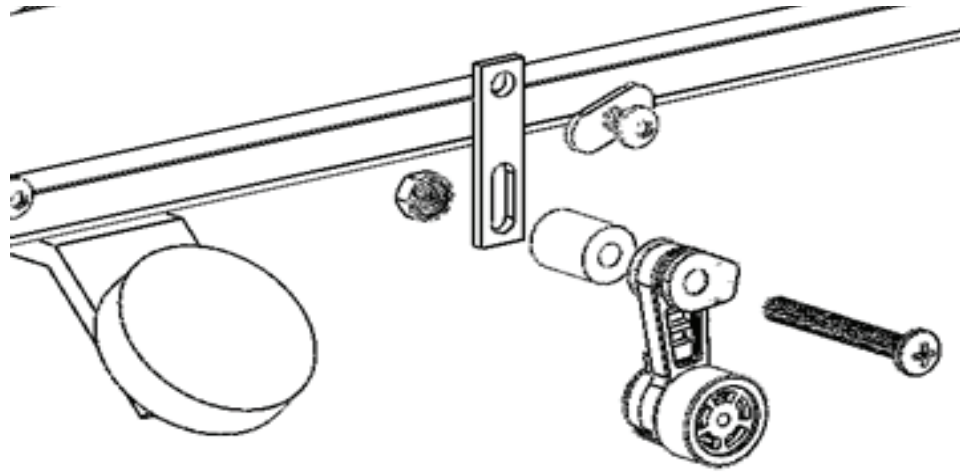

2 Attach the Encoder bracket to the carriage of the machine using the provided T nut screw.

3 Once the Encoder bracket has been attached you can proceed to attach the encoder using the hardware that was provided.

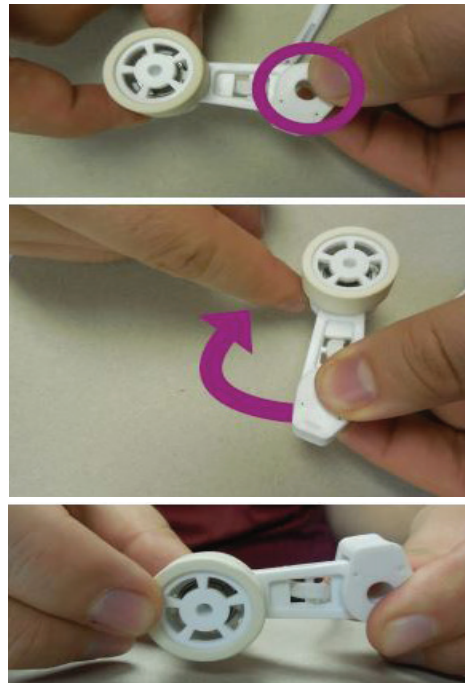

4 Use the next few pictures as a reference.

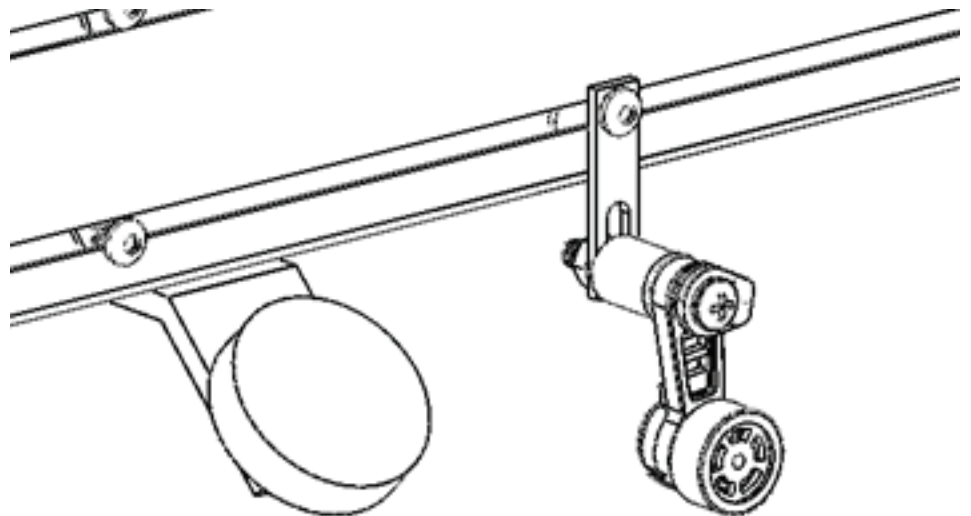

Encoder Installation

5 The encoders will be plugged into the designated ports.

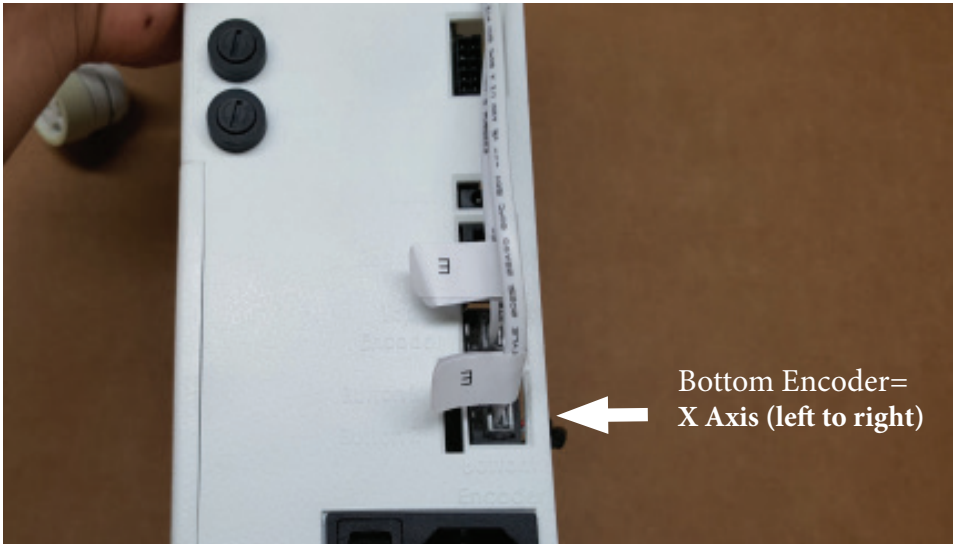
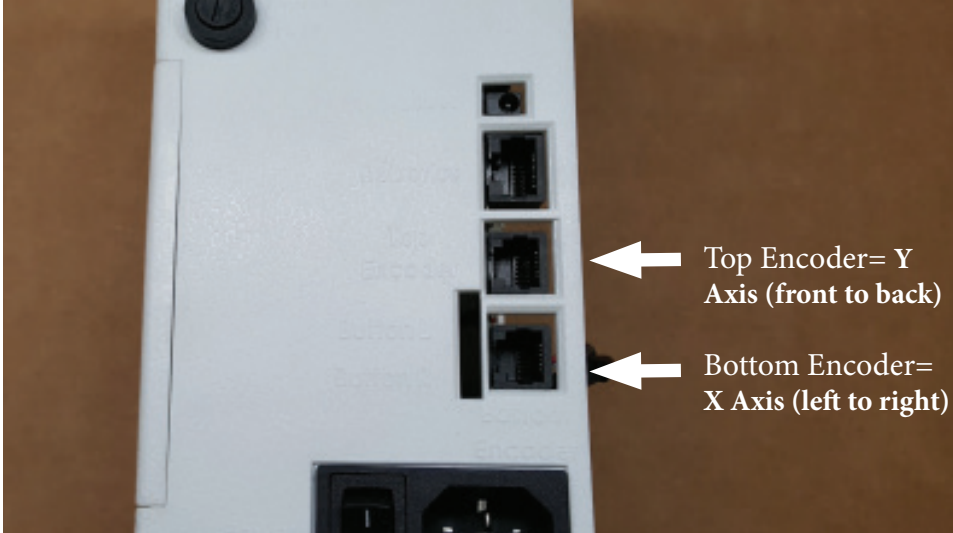

- 1 Upon completion your machine should look like the picture to the right.

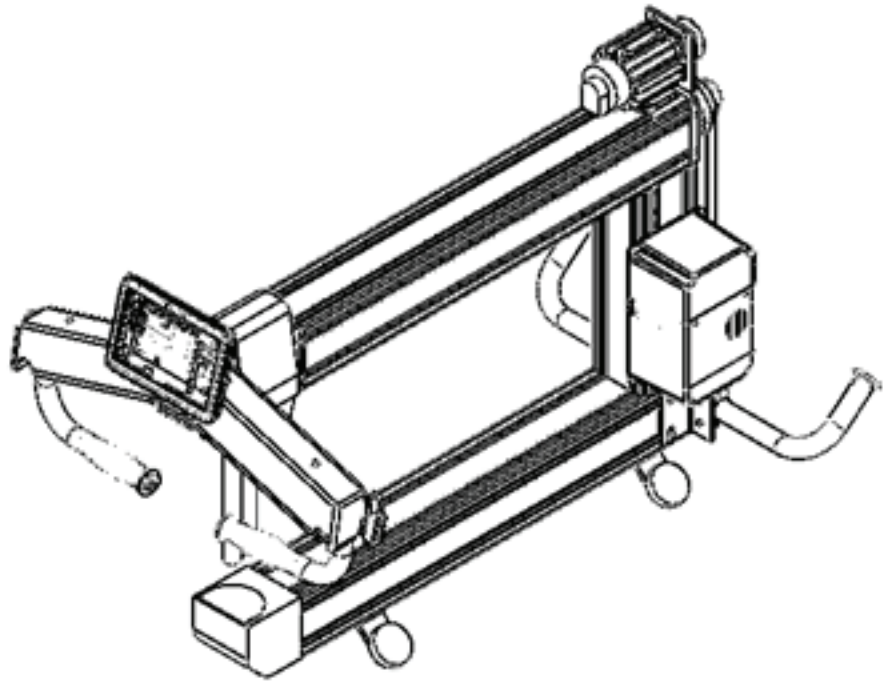



Still need help?

Visit quilt-ez.com to learn how to contact us and find additional help material.