



**How to Attach  
Butler Robotics to a  
Nolting  
(Hinterberg Summit)**

**In order to accommodate all machine types we use universal parts bags, not all parts will be used in every installation.**

**Bag #**

**Contents**

**Picture**

**Cables**

Vary by machine



**X1**

1-White belt (12’)  
4 - Plastic belt clamps  
4 - Screw (4-40 x 0.5)



**Y1**

1 - Black Belt (86’)  
4 - Plastic Belt Clamps  
4 - Screw (4-40 x 0.5)



**Z2**

5- Plastic Anchors  
2- Screw (M5 x 12mm)  
2- Washer (M5)  
1- Stylus  
5-Zip ties  
1- Drill bit (5/16’)



**Z3**

1 - Motor Pulley Cover  
2 - Nuts (M5 K-lock)



**X2**

- 2- X-belt brackets (Side A)
- 2- X-belt brackets (Side B)
- 4- Pan head screws (M5 x 25mm)
- 2- Eye-bolts (M5 x 40mm)
- 8- Nuts (M5 K-lock)



**D2**

- 1- Display bracket
- 2- Screw (M3 x 8mm)
- 2-Remote base
- 4- Screw (M6 x 8)
- 4- Nut (M6)
- 2- Poly disc
- 2- Screw (M3 x 8mm)



**Y19**

- 1- Carriage bracket
- 1- Universal Y-bracket
- 1-Thumb screw (10-24 x 1/2")
- 1- Eye-bolt (M5 x 40mm)
- 1- Pan head screw ((10-24 x 1/4")
- 2- Nuts (M5 K-lock)
- 2- Pan head screws (10-24 x 3/4")



**I9**

- 1-Rear idler bracket
- 1-Shoulder screw
- 3- Nuts (10-24 K-lock)
- 1-Motor pulley
- 1-Poly disc washer
- 2- Pan head screws (10-24 x 1/2")



**M9**

- 1- Motor box bracket
- 2- Pan head screws (M5 x 12)
- 3- Pan head screws (10-24 x 1/2")
- 3- Nuts (10-24 K-lock)



## Attach the Front Carriage Bracket (Bag M9)

- 1** Align the motor box bracket with the holes on the front carriage.

Use the provided 10-24 x 1/2" screws and nuts to fasten the bracket to the front of the carriage.

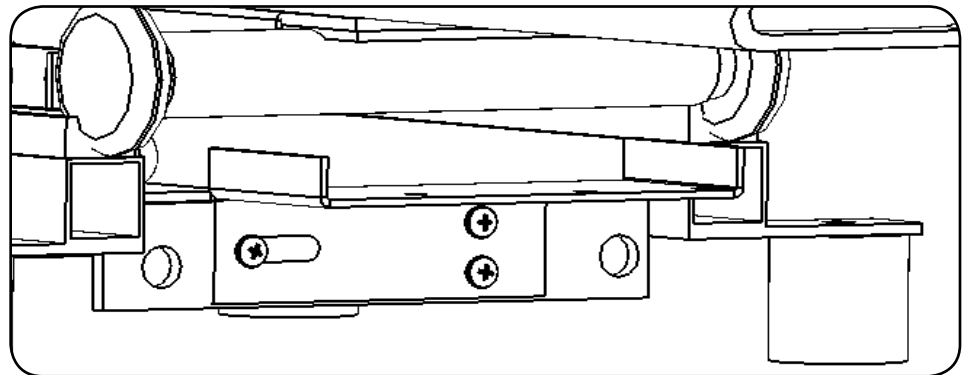
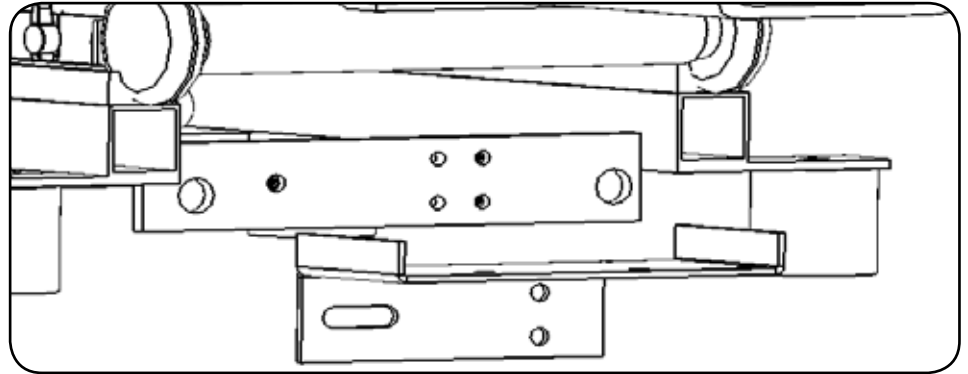

- 2** Attach motor box to bracket with provided M5 x 12mm screws.

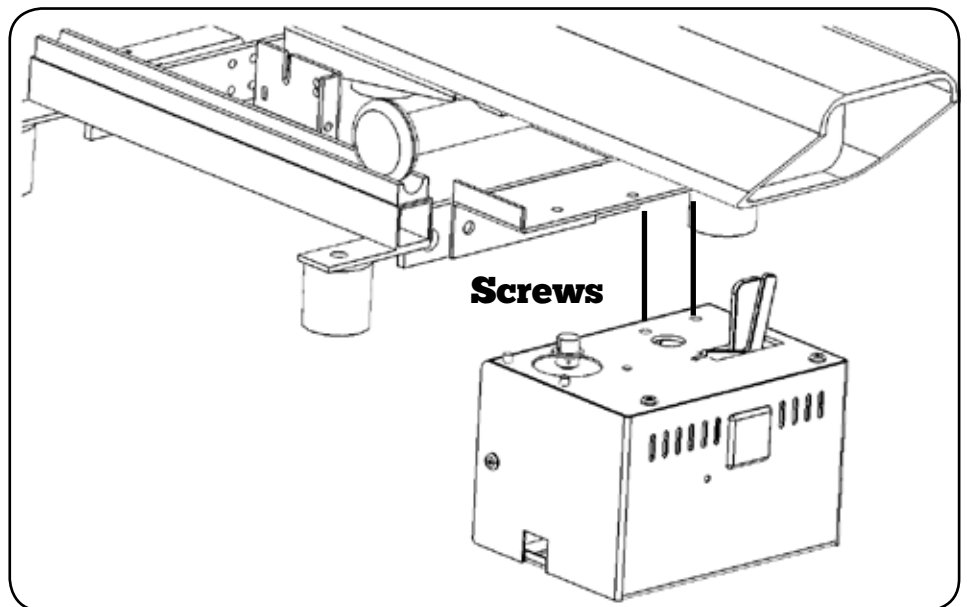

## Attach the Rear Idle Bracket (Bag I9)

- 1** Align the rear idler bracket with the two right most holes at the rear of the carriage.

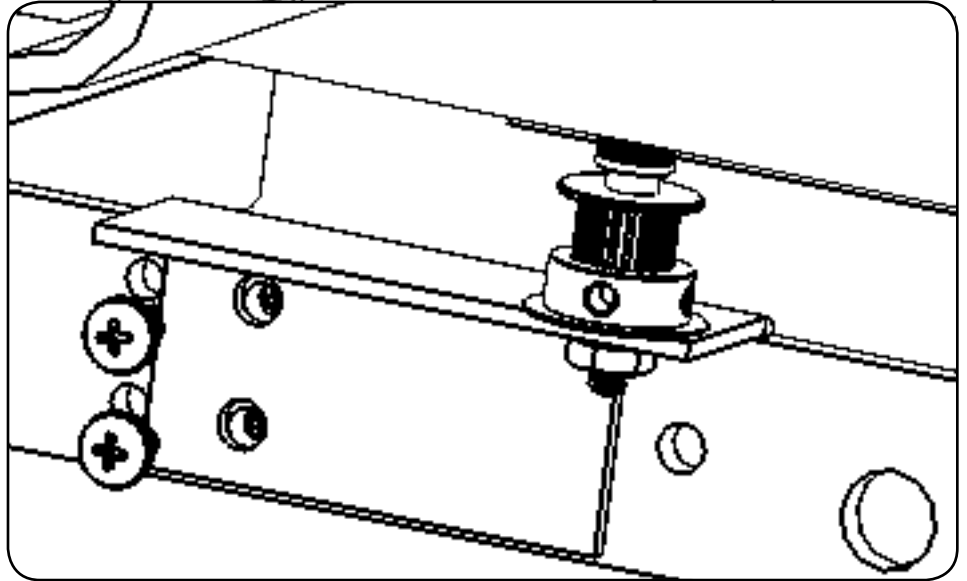

- 2** Install the bracket with the provided 10-24 x 1/2" screws and nuts.

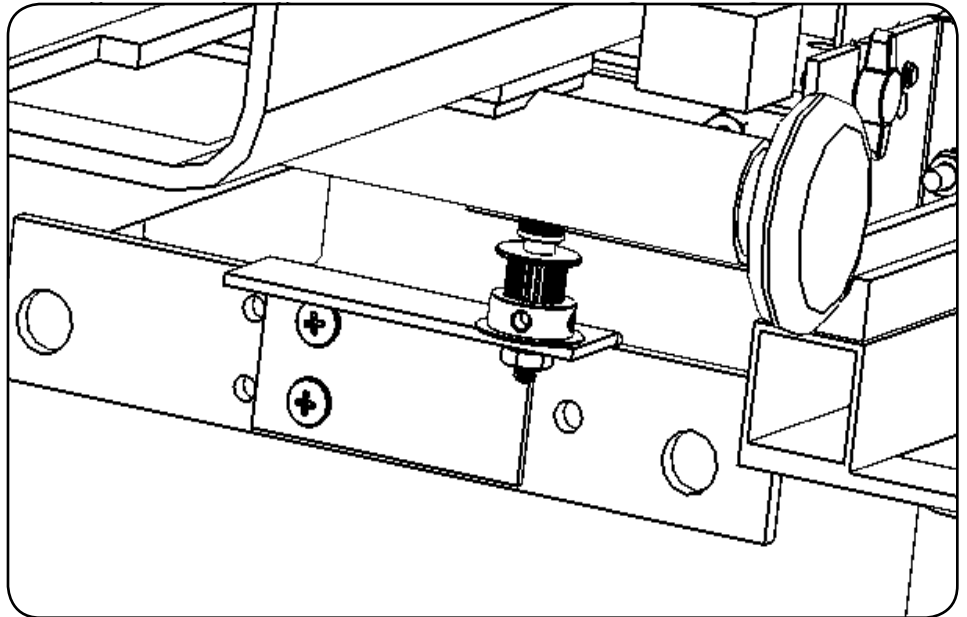

## Attach the Black Belt (Bag Y1 and Bag Y19)

- 1** Take the machine off the carriage, and remove the front wheel axle

Insert the carriage bracket between the wheels and the machine.

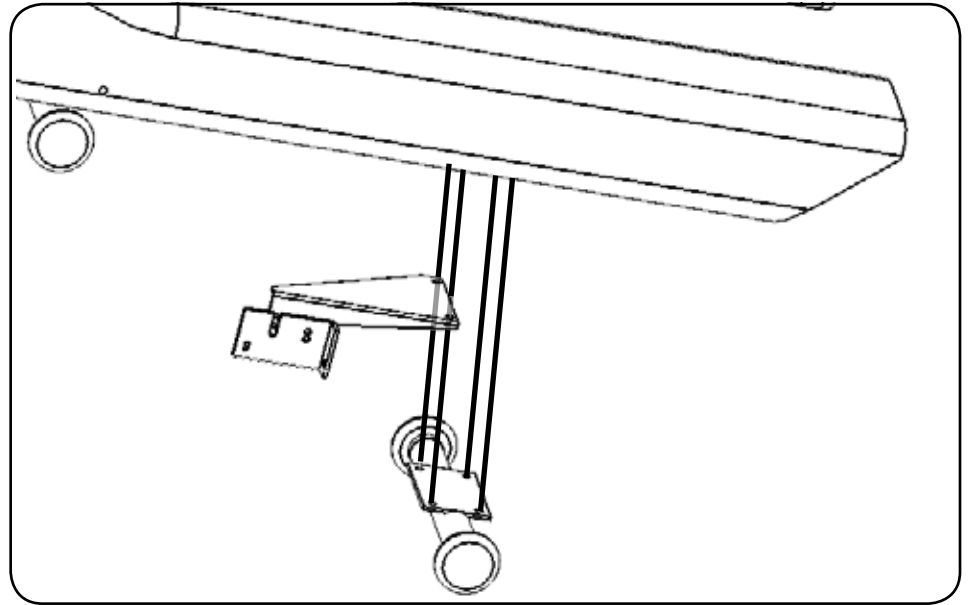

- 2** Align the holes on the carriage bracket with the holes on the axle and reattach the screws as shown.

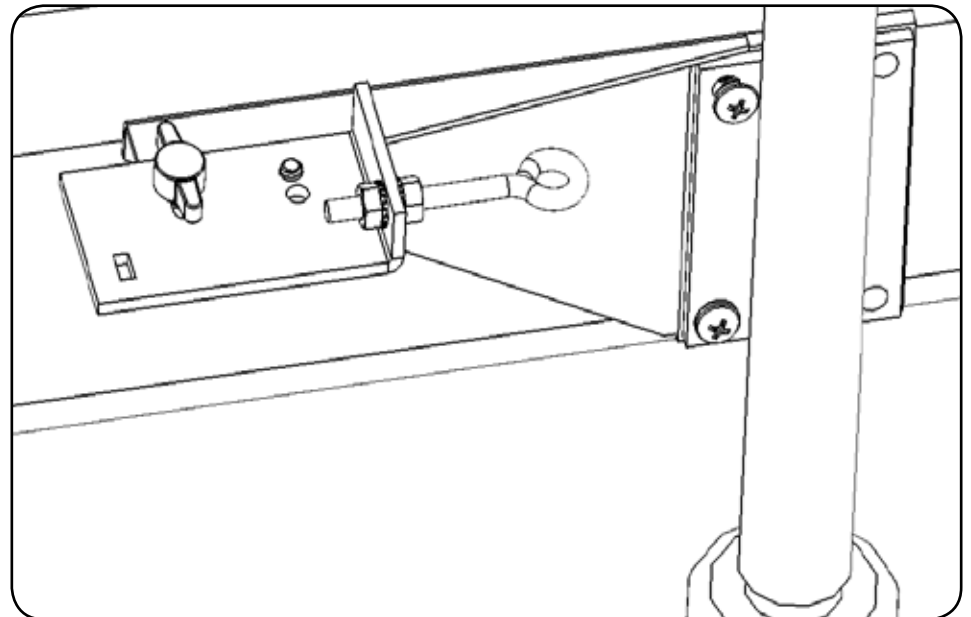

- 3** Attach one end of the black belt to the eyebolt with the teeth facing the machine, using a belt clamp.

See Appendix A for help with belt clamps.

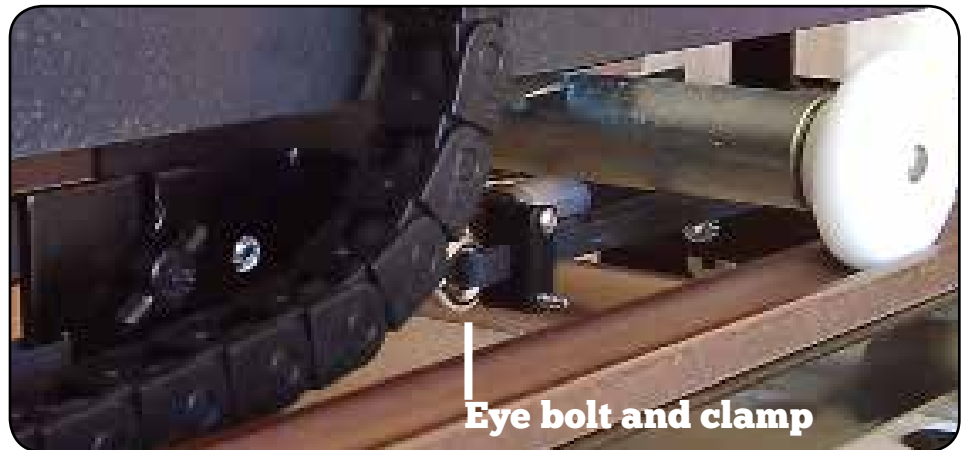

- 4** Run the belt around the pulley on the top of the motor box, behind the carriage bracket, and around the rear idler pulley

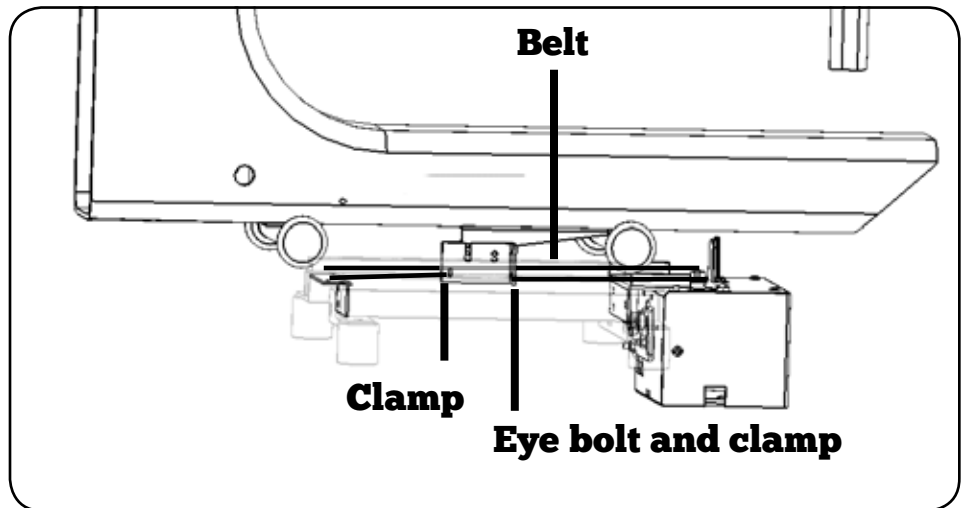

- 5** Attach the other side of the belt to the slot on the carriage bracket using another belt clamp.



## Attach the White Belt (Bag X1 and Bag X2)

**1** Clamp the X-belt brackets to the joint on the side of the frame with the eye-bolt facing in.

Repeat for both sides.



**2** Use belt clamps to attach the white belt to the eye-bolts on each side with the teeth facing up.

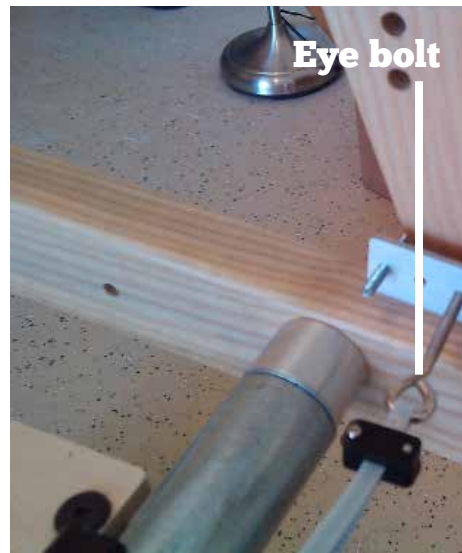



**3** Disengage the locking lever on the top of the motor box and run the belt through the pulleys as shown.

Engage the locking lever to remove belt tension.



# Install the Android 10" Display (Bag D2)

**1** *For machines with PerfectStitch upgrade skip these steps and go directly to the "Android Installation Guide."*

Mount the tablet bracket to the display bracket.

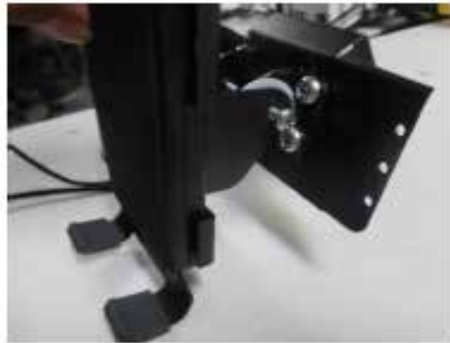

**2** Loosen the faceplate screws and slide the display bracket tab into the gap.

Tighten the screws to secure the display bracket.

*Refer to the "Android Installation Guide" for instructions on how to install the tablet.*



Image not representative of the Android tablet, but the concept is the same

# Install Standard Display (Bag D2)

**1**

Insert SD card into display.  
Attach display to display bracket with provided screws.



Install display onto the machine using the provided screws.



**2**

Loosen faceplate screws and slide display bracket tab between faceplate and machine head. Tighten faceplate screws.



# Connect Cables

## Connect the power cable

- 1** Plug the power cable into the port on the motor box.

Ensure that the cable is running towards the top of the motor box and not towards the ground.



- 2** Run the cable along the carriage to the back of the machine, and then plug into the outlet or power source.

*For Standard model  
continue to next page.*

*For Pro model  
continue to page 16.*

*For PerfectStitch  
continue to page 19.*



\*Image not representative of all machine types.

- 1** For Standard Model  
Plug the Y- handlebar cable into the handle bar port of the black motor box.



- 2** Run the handlebar cable along the base of the carriage to the back handlebars.



\*Image not representative of all machine types.

- 3** Disconnect the handlebar cable on the right rear handlebar.

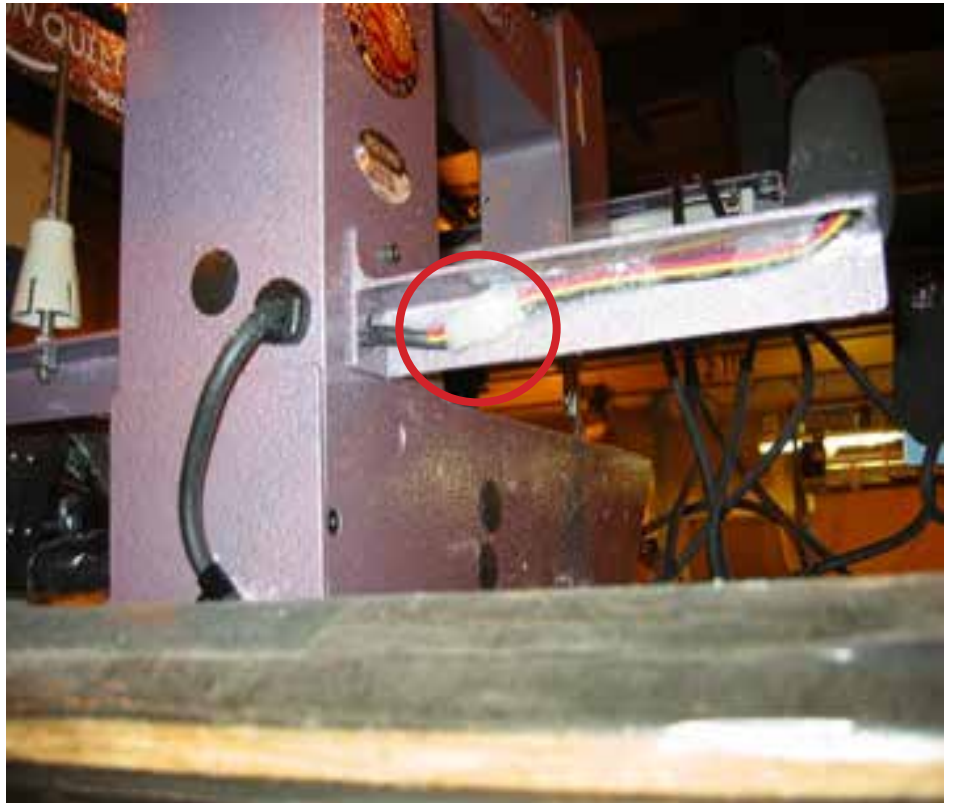

- 4** Take the split side of the Start/Stop wire, and connect into each port.

The start stop wire will 'T' into the existing handlebar wire.

Repeat on the left side for the Needle Up wire.

*If the machine handlebar wires on only one side the needle up wire is unnecessary.*

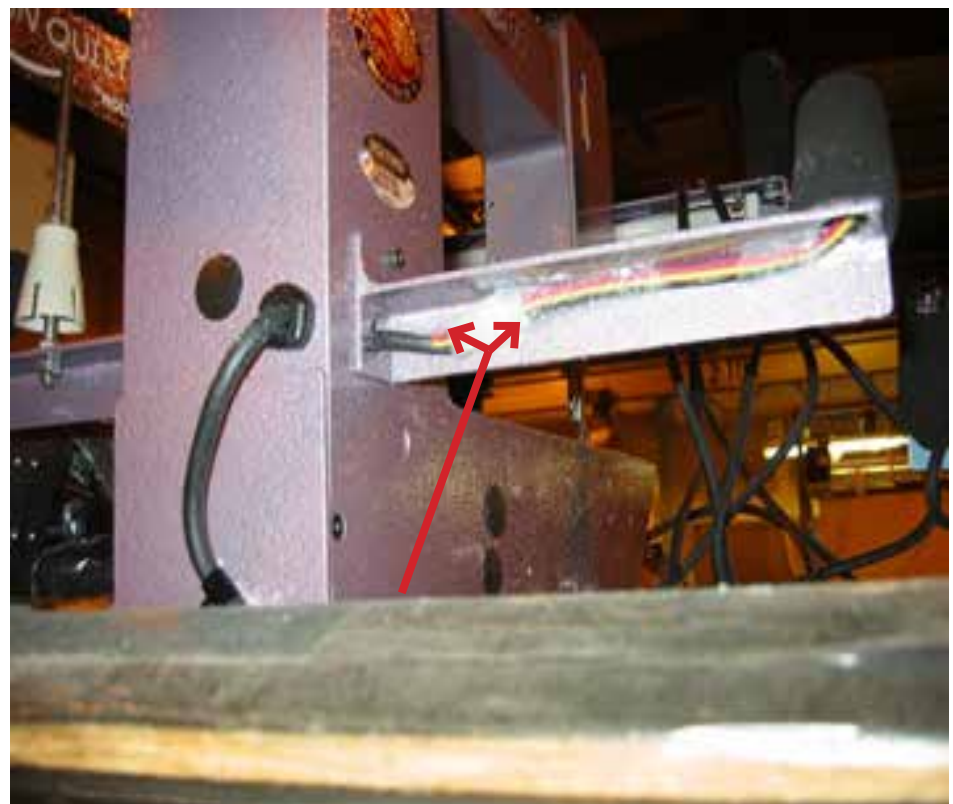

**5** Plug the network style cable into the “Remote” port on the motor box.

*Note: You will only have one of the cables pictured.*



**6** Run the cable with the handlebar cable around the back of the machine up to the display.

Use the provided anchors and zip-ties to secure the cables to the carriage. Make sure they are out of the way of any moving parts.

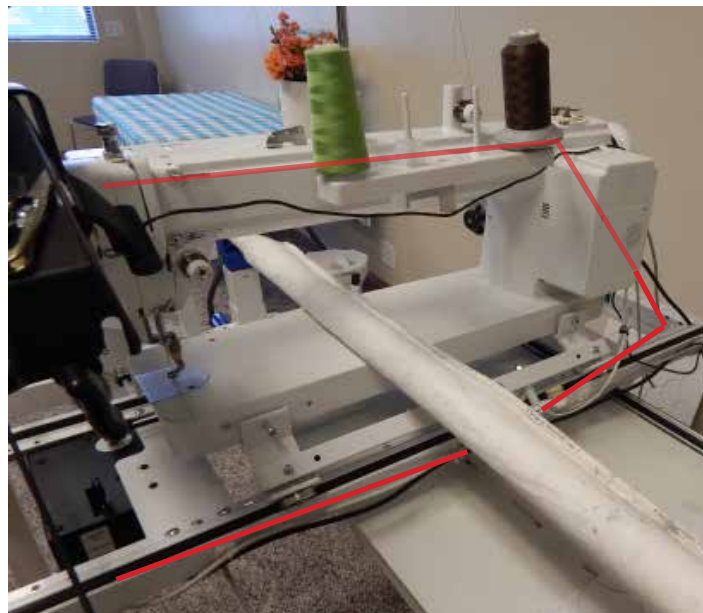

**7** Connect the other end of the display cable into the display.

Android cables will plug into the RJ45 network connection on the hub on the back of the tablet.

Standard displays will plug into the slot on the bottom of the display.



**Pro Model**

**1** Plug the handlebar cable into the handle bar port of the black motor box.





- 2** Run the handlebar cable along the base of the carriage to the back handlebars.

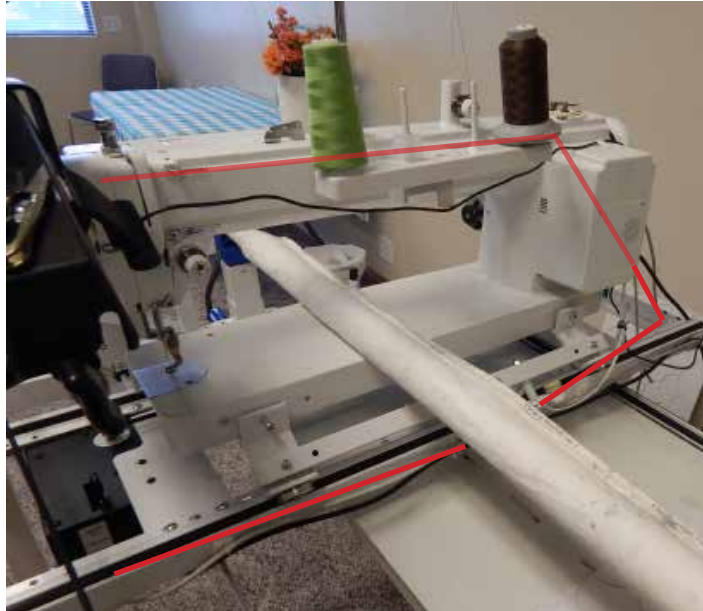

- 3** Remove the front faceplate of the stitch regulator.

Loosen the screw for the terminals labeled start, GND, and SS.

Connect the ground (green) from both Needle Up and Start/Stop cables into the GND port.

Connect the control wire from the Start/Stop wire into Start terminal.

Connect the control wire from Needle Up cable into SS terminal.

Reattach the faceplate.

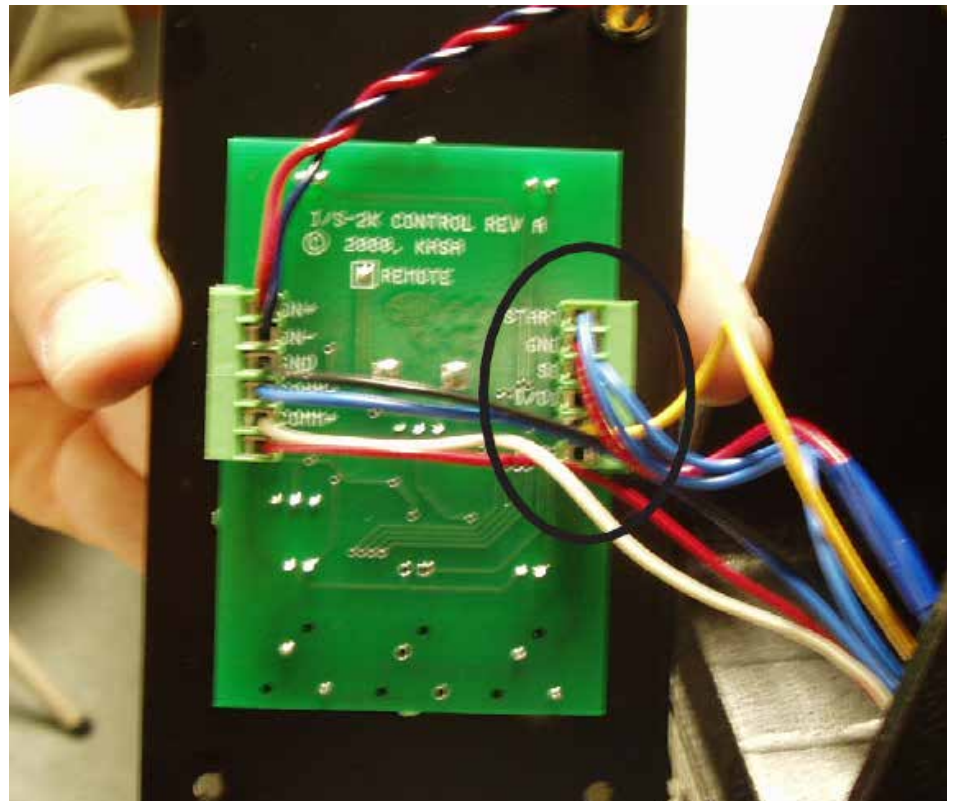

- 4** Plug the network style cable into the “Remote” port on the motor box.

*Note: You will only have one of the cables pictured.*



- 5** Run the cable with the handlebar cable around the back of the machine up to the display.

Use the provided anchors and zip-ties to secure the cables to the carriage. Make sure they are out of the way of any moving parts.

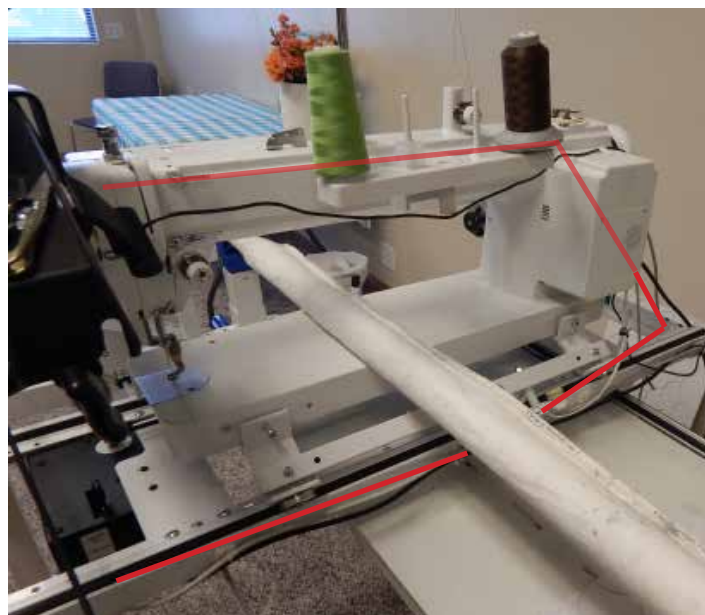

**6** Connect the other end of the display cable into the display.

Android cables will plug into the RJ45 network connection on the hub on the back of the tablet.

Standard displays will plug into the slot on the bottom of the display.



### For PerfectStitch

**1** Plug the remaining end into the Stitcher Box port on Butler.



**2** Run the cable along the carriage with the power cable to the control box and plug into the robotics port on the PCB.

Use the provided anchors and zip-ties to secure the cables to the carriage. Make sure they are out of the way of any moving parts.



\*Image not representative of all machine types.



# Set Machine Type

**Important: If the machine has been upgraded to PerfectStitch, then the machine type is to be set to Default.**

## Android Tablet

- 1 Power on the display, go to Settings > Machine and set the machine type to Nolting.

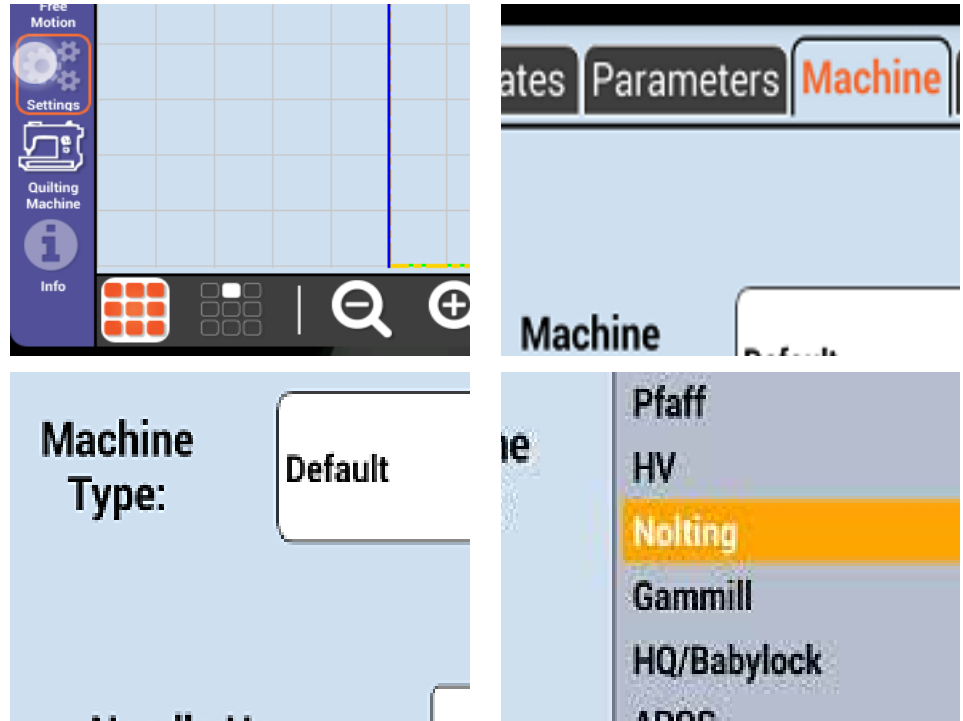

## Standard Display

- 1 Power on the display, go to Setup > Advanced and set the machine type to Nolting.

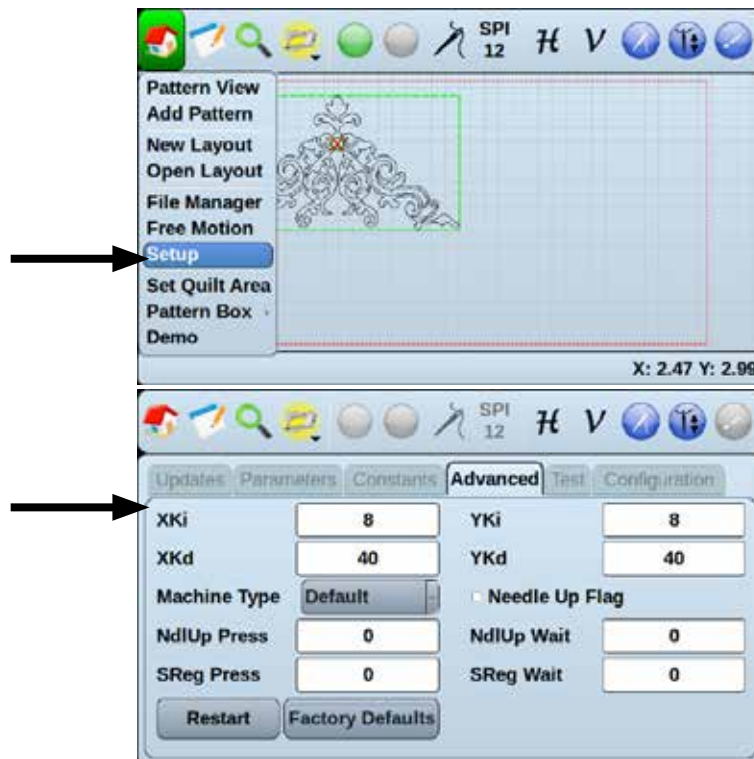

## Check Belt Tension

**1** Adjust the belt tension by tightening the nuts on the eye-bolts.

The black belt should have about 1/4" of play while the white belt should have between 1" and 1 1/2" of play with the machine in the middle of the frame.

Loosen the nut closest to the eye.



Pull the belt tight and tighten the other nut.

## Appendix A - How to use Belt Clamps

A belt clamp consists of two clamps and two screws.



- 1** Using a Phillips screwdriver, insert each screw on opposite sides of the clamps and tighten halfway.

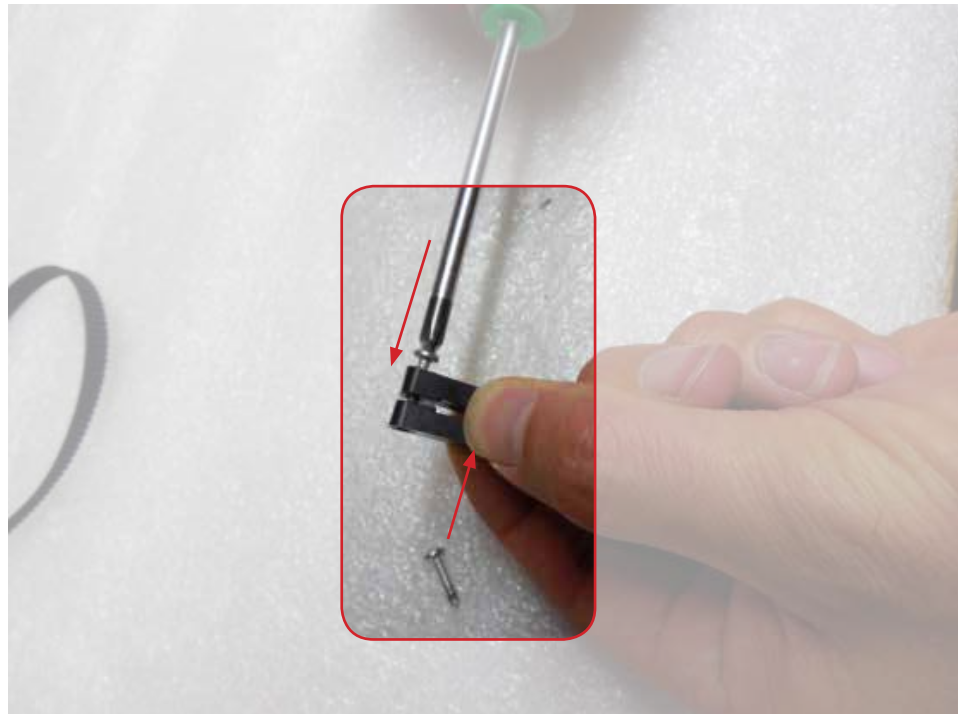

**2**

Thread the belt between the clamps, loop it around and reinsert it between the clamps.



**3**

Align the belt teeth, then finish tightening the clamps.





# Appendix B- Additional help

## Power on the robotics

Use the power switch located on the side of the motor box with the ports to power the motor box off and on.



## Disengage belts for free motion

In order to use free motion with the butler connected the belts will need to be disengaged.

To disengage the x-belt, move the locking lever away from the edge of the motor box.

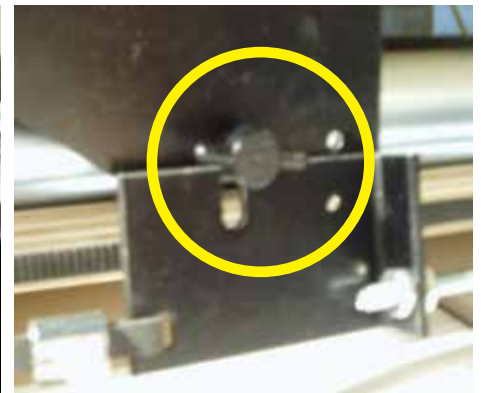

To disengage the y-belt, loosen the wing-nut on the carriage bracket.

You can now use free motion quilting.



## **Still need help?**

Visit [quilt-ez.com](http://quilt-ez.com) to learn how to contact us and find additional help material.